

RELIABILITY REPORT
FOR
MAX489ExxD
PLASTIC ENCAPSULATED DEVICES

November 19, 2002

MAXIM INTEGRATED PRODUCTS

120 SAN GABRIEL DR.

SUNNYVALE, CA 94086

Written by



Jim Pedicord
Quality Assurance
Reliability Lab Manager

Reviewed by



Bryan J. Preeshl
Quality Assurance
Executive Director

Conclusion

The MAX489E successfully meets the quality and reliability standards required of all Maxim products. In addition, Maxim's continuous reliability monitoring program ensures that all outgoing product will continue to meet Maxim's quality and reliability standards.

Table of Contents

I.Device Description	V.Quality Assurance Information
II.Manufacturing Information	VI.Reliability Evaluation
III.Packaging Information	
IV.Die InformationAttachments

I. Device Description

A. General

The MAX489E is a low-power transceiver for RS-485 and RS-422 communications in harsh environments. Each driver output and receiver input is protected against $\pm 15\text{kV}$ electrostatic discharge (ESD) shocks, without latchup. This part contains one driver and one receiver. The MAX489E features reduced slew-rate drivers that minimize EMI and reduce reflections caused by improperly terminated cables, thus allowing error-free data transmission up to 250kbps.

This transceiver draws as little as $120\mu\text{A}$ supply current when unloaded or when fully loaded with disabled drivers (see Selection Table).

Drivers are short-circuit current limited, and are protected against excessive power dissipation by thermal shutdown circuitry that places their outputs into a high-impedance state. The receiver input has a fail-safe feature that guarantees a logic-high output if the input is open circuit.

The MAX489E is designed for full-duplex communications

B. Absolute Maximum Ratings

<u>Item</u>	<u>Rating</u>
Supply Voltage (V_{CC})	12V
Control Input Voltage (/RE, DE)	-0.5V to ($V_{CC} + 0.5\text{V}$)
Driver Input Voltage (DI)	-0.5V to ($V_{CC} + 0.5\text{V}$)
Driver Output Voltage (Y, Z; A,B)	-8V to +12.5V
Receiver Input Voltage (A, B)	-8V to +12.5V
Receiver Output Voltage (RO)	-0.5V to ($V_{CC} + 0.5\text{V}$)
Storage Temp.	-65°C to +160°C
Lead Temp. (10 sec.)	+300°C
Power Dissipation	830mW
Derates above +70°C	4.1mW/°C
Continuous Power Dissipation ($T_A = +70^\circ\text{C}$)	
14-Pin Plastic DIP	800mW
14-Pin NSO	667mW
Derate above +70°C	
14-Pin Plastic DIP	10.0mW/°C
14-Pin NSO	8.33mW/°C

II. Manufacturing Information

- A. Description/Function: $\pm 15\text{kV}$ ESD-Protected, Slew-Rate-Limited, Low-Power, RS-485/RS-422 Transceiver
- B. Process: S3 (Standard 3 micron silicon gate CMOS)
- C. Number of Device Transistors: 295
- D. Fabrication Location: Oregon, USA
- E. Assembly Location: Malaysia, Philippines or Thailand
- F. Date of Initial Production: October, 1995

III. Packaging Information

- | | | |
|---|--------------------------|--------------------------|
| A. Package Type: | 14-Lead PDIP | 14-Lead SO |
| B. Lead Frame: | Copper | Copper |
| C. Lead Finish: | Solder Plate | Solder Plate |
| D. Die Attach: | Silver-filled Epoxy | Silver-filled Epoxy |
| E. Bondwire: | Gold (1.3 mil dia.) | Gold (1.3 mil dia.) |
| F. Mold Material: | Epoxy with silica filler | Epoxy with silica filler |
| G. Assembly Diagram: | # 05-1901-0140 | # 05-1901-0141 |
| H. Flammability Rating: | Class UL94-V0 | Class UL94-V0 |
| I. Classification of Moisture Sensitivity per JEDEC standard JESD22-A112: | Level 1 | Level 1 |

IV. Die Information

- A. Dimensions: 85 x 128 mils
- B. Passivation: $\text{Si}_3\text{N}_4/\text{SiO}_2$ (Silicon nitride/ Silicon dioxide)
- C. Interconnect: Aluminum/Si (Si = 1%)
- D. Backside Metallization: None
- E. Minimum Metal Width: 3 microns (as drawn)
- F. Minimum Metal Spacing: 3 microns (as drawn)
- G. Bondpad Dimensions: 5 mil. Sq.
- H. Isolation Dielectric: SiO_2
- I. Die Separation Method: Wafer Saw

V. Quality Assurance Information

- A. Quality Assurance Contacts: Jim Pedicord (Manager, Reliability Operations)
Bryan Preeshl (Executive Director)
Kenneth Huening (Vice President)
- B. Outgoing Inspection Level: 0.1% for all electrical parameters guaranteed by the Datasheet.
0.1% For all Visual Defects.
- C. Observed Outgoing Defect Rate: < 50 ppm
- D. Sampling Plan: Mil-Std-105D

VI. Reliability Evaluation

A. Accelerated Life Test

The results of the 135°C biased (static) life test are shown in **Table 1**. Using these results, the Failure Rate (λ) is calculated as follows:

$$\lambda = \frac{1}{\text{MTTF}} = \frac{1.83}{192 \times 4389 \times 1360 \times 2} \quad (\text{Chi square value for MTTF upper limit})$$

└ Temperature Acceleration factor assuming an activation energy of 0.8eV

$$\lambda = 0.80 \times 10^{-9}$$

$$\lambda = 0.80 \text{ F.I.T. (60\% confidence level @ 25°C)}$$

This low failure rate represents data collected from Maxim's reliability monitor program. In addition to routine production Burn-In, Maxim pulls a sample from every fabrication process three times per week and subjects it to an extended Burn-In prior to shipment to ensure its reliability. The reliability control level for each lot to be shipped as standard product is 59 F.I.T. at a 60% confidence level, which equates to 3 failures in an 80 piece sample. Maxim performs failure analysis on any lot that exceeds this reliability control level. Attached Burn-In Schematic (Spec. # 06-0053) shows the static Burn-In circuit. Maxim also performs quarterly 1000 hour life test monitors. This data is published in the Product Reliability Report (**RR-1M**).

B. Moisture Resistance Tests

Maxim pulls pressure pot samples from every assembly process three times per week. Each lot sample must meet an LTPD = 20 or less before shipment as standard product. Additionally, the industry standard 85°C/85%RH testing is done per generic device/package family once a quarter.

C. E.S.D. and Latch-Up Testing

The RS29-7 die type has been found to have all pins able to withstand a transient pulse of $\pm 3000\text{V}$, per Mil-Std-883 Method 3015 (reference attached ESD Test Circuit). Additionally, the MAX485E has achieved $\pm 15\text{kV}$ ESD protection using both methods 3015 and IEC 801-2 (air-gap discharge) on the I/O pins.

Latch-Up testing has shown that this device withstands a current of $\pm 250\text{mA}$ and/or $\pm 20\text{V}$.

Table 1
Reliability Evaluation Test Results
MAX489ExxD

TEST ITEM	TEST CONDITION	FAILURE IDENTIFICATION	PACKAGE	SAMPLE SIZE	NUMBER OF FAILURES
Static Life Test (Note 1)					
	Ta = 135°C Biased Time = 192 hrs.	DC Parameters & functionality		1360	0
Moisture Testing (Note 2)					
Pressure Pot	Ta = 121°C P = 15 psi. RH= 100% Time = 96hrs.	DC Parameters & functionality	PDIP NSO	77 77	0 0
85/85	Ta = 85°C RH = 85% Biased Time = 1000hrs.	DC Parameters & functionality		77	0
Mechanical Stress (Note 2)					
Temperature Cycle	-65°C/150°C 1000 Cycles Method 1010	DC Parameters		77	0

Note 1: Life Test Data may represent plastic D.I.P. qualification lots.

Note 2: Generic process/package data

Attachment #1

TABLE II. Pin combination to be tested. 1/ 2/

	Terminal A (Each pin individually connected to terminal A with the other floating)	Terminal B (The common combination of all like-named pins connected to terminal B)
1.	All pins except V_{PS1} 3/	All V_{PS1} pins
2.	All input and output pins	All other input-output pins

1/ Table II is restated in narrative form in 3.4 below.

2/ No connects are not to be tested.

3/ Repeat pin combination I for each named Power supply and for ground

(e.g., where V_{PS1} is V_{DD} , V_{CC} , V_{SS} , V_{BB} , GND, $+V_S$, $-V_S$, V_{REF} , etc).

3.4 Pin combinations to be tested.

- Each pin individually connected to terminal A with respect to the device ground pin(s) connected to terminal B. All pins except the one being tested and the ground pin(s) shall be open.
- Each pin individually connected to terminal A with respect to each different set of a combination of all named power supply pins (e.g., V_{SS1} , or V_{SS2} or V_{SS3} or V_{CC1} , or V_{CC2}) connected to terminal B. All pins except the one being tested and the power supply pin or set of pins shall be open.
- Each input and each output individually connected to terminal A with respect to a combination of all the other input and output pins connected to terminal B. All pins except the input or output pin being tested and the combination of all the other input and output pins shall be open.

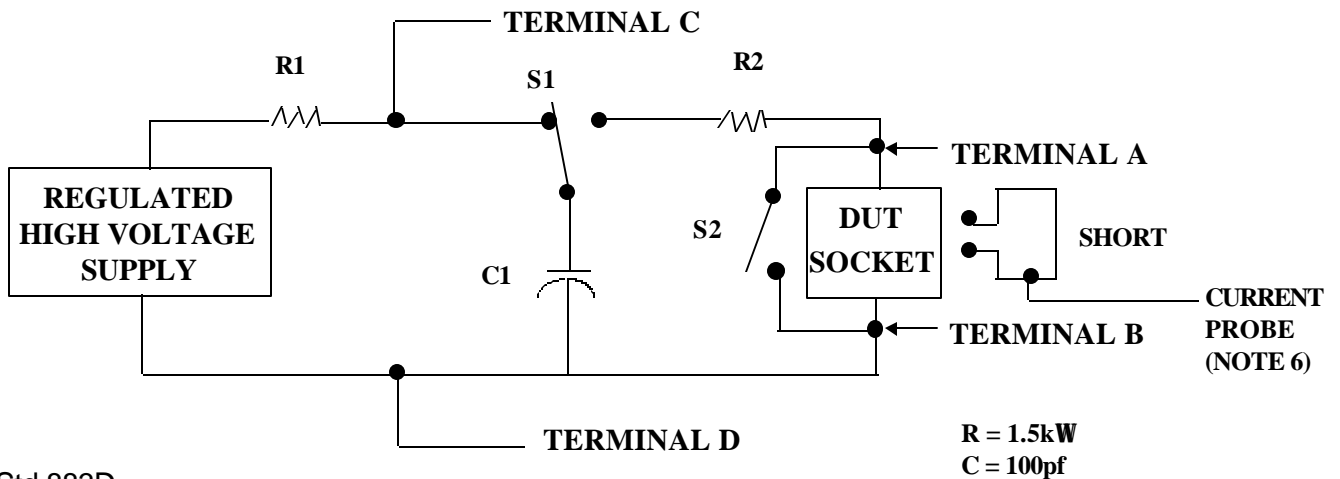

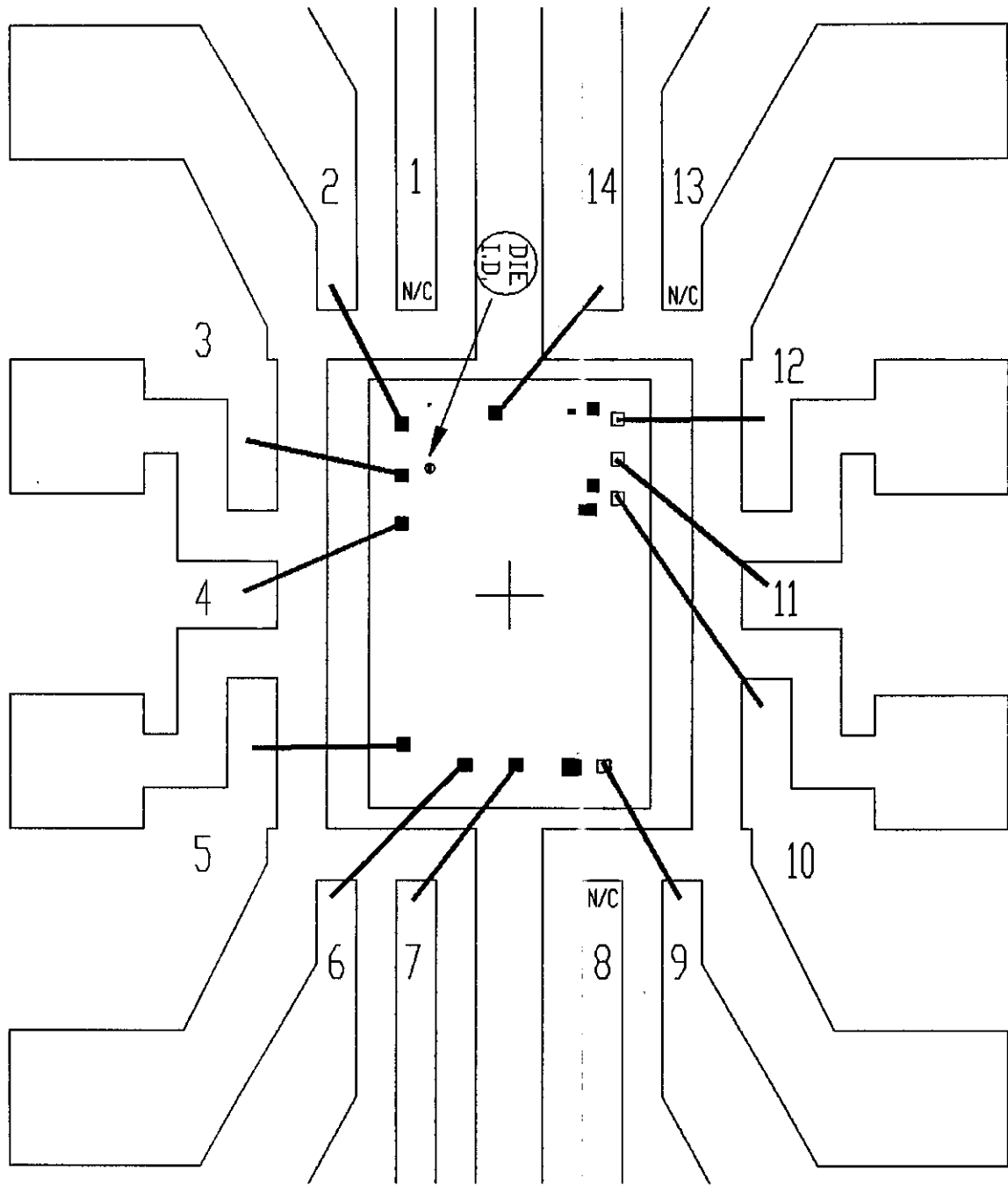

PKG.CODE: P14-3	
CAV./PAD SIZE: 110 X 140	PKG. DESIGN

APPROVALS

DATE

MAXIM	
BUILDSHEET NUMBER: 05-1901-0140	REV.: A

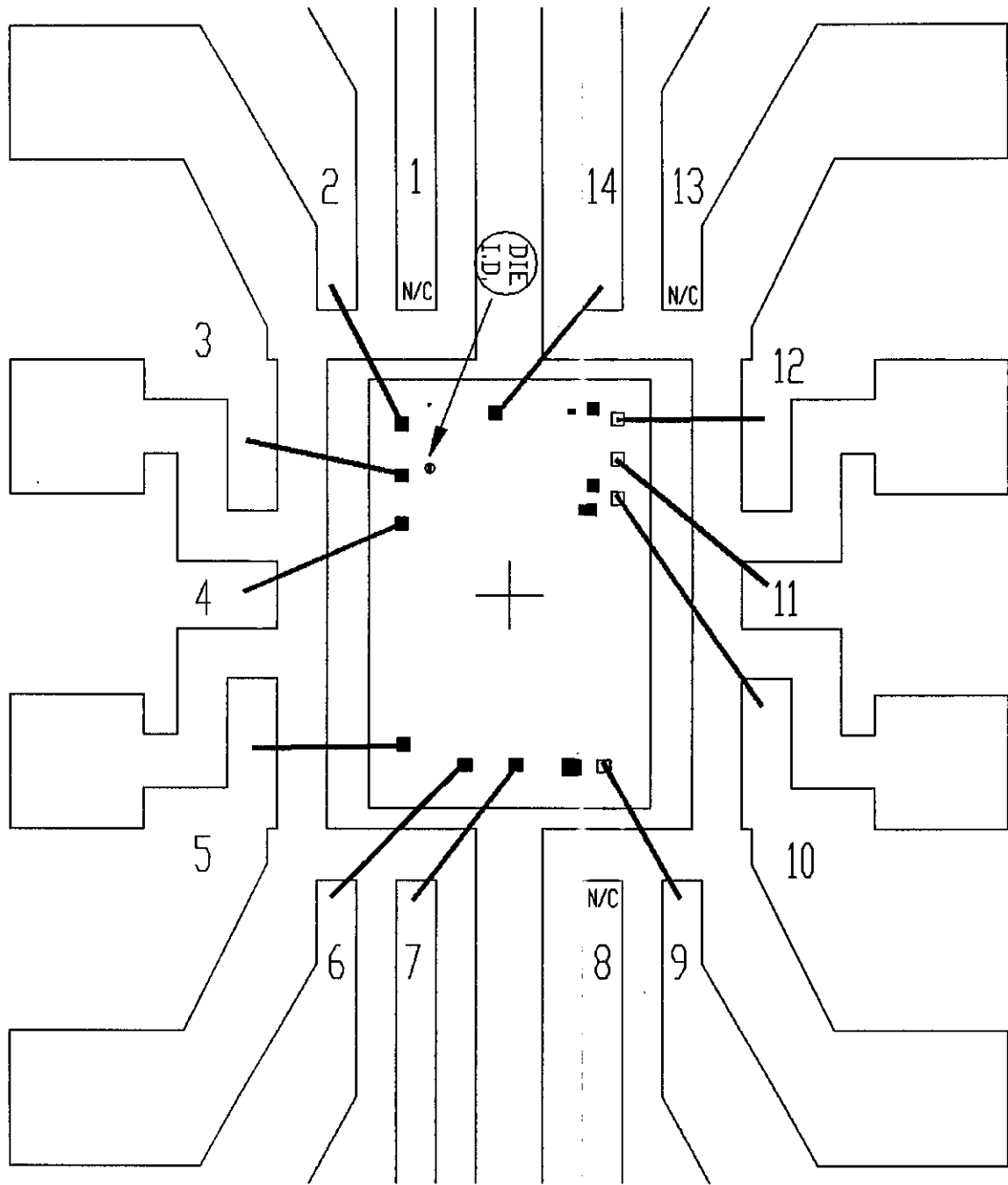

PKG.CODE: P14-3

CAV./PAD SIZE:
110 X 140

PKG.
DESIGN

APPROVALS

DATE

MAXIM

BUILDSHEET NUMBER:
05-1901-0140

REV:
A

ONCE PER BOARD

ONCE PER SOCKET

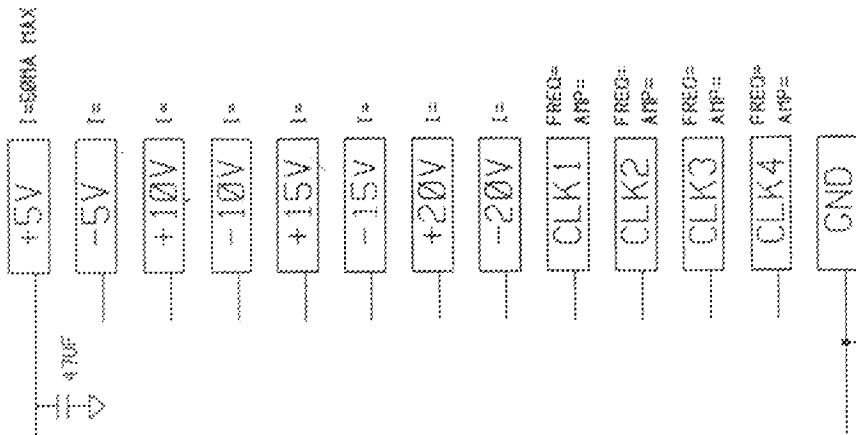
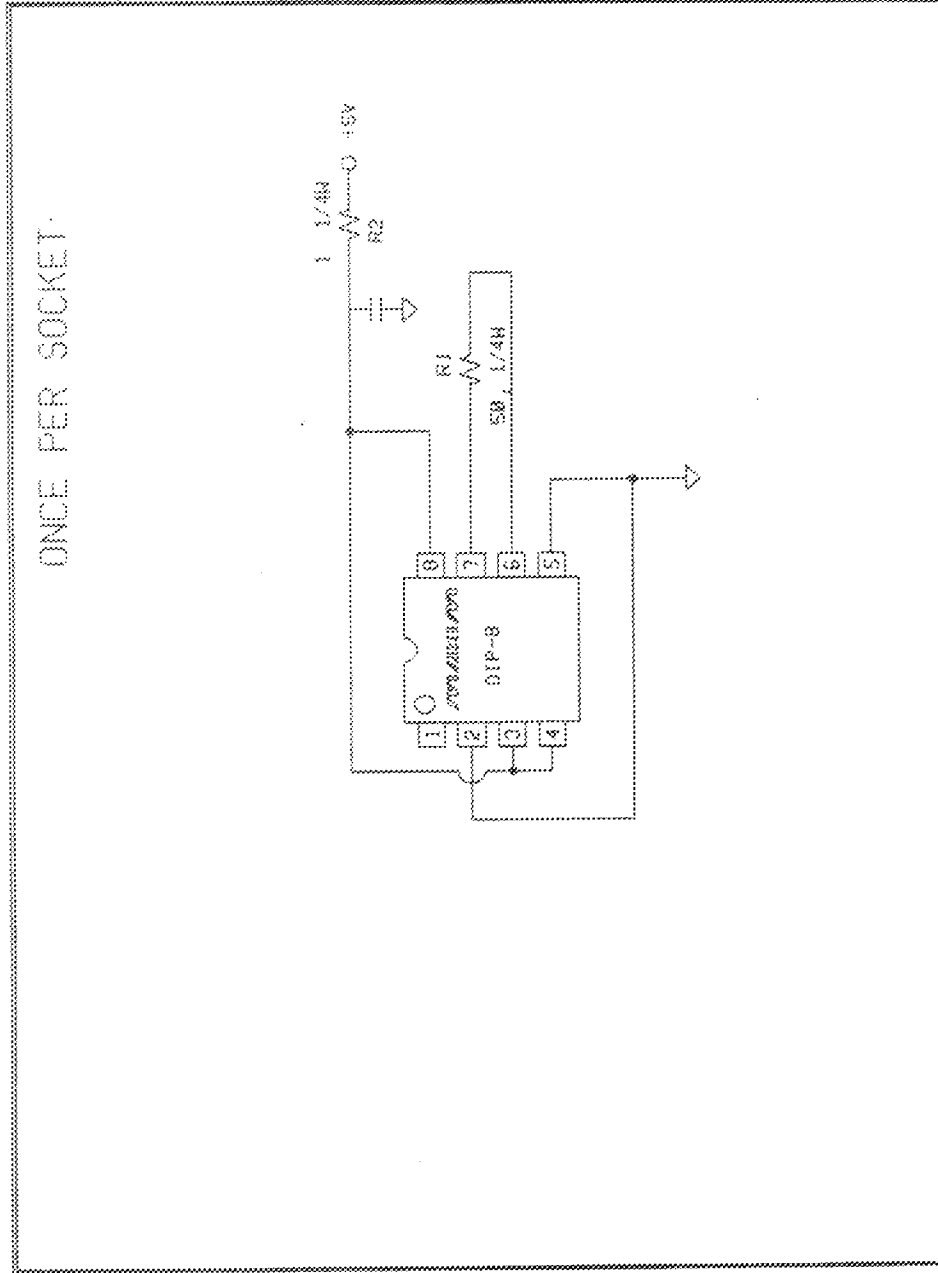

— STEADY STATE LIFE TEST IS PER MIL-STD-883 METHOD 1005.
 — BURN-IN IS PER MIL-STD-883 METHOD 1015. COND. C

NOTES:

1. TEMPERATURE: 125C OR EQUIVALENT
2. TIME: 168 HOURS MIN. OR EQUIVALENT
3. ALL COMPONENTS AND MATERIAL MUST STAND 150C CONTINUOUS
4. APPROVED FOR (X) CONFIDENTIAL (X) HR/583

SPEC. NO. 06-0053 REV. D

DATE: 8/20/99

DRAWN BY:

MINIMUM BURN-IN SCHEMATIC

DEVICE TYPE:

MAX481/483/485/487/1487
 MAX1483 MAX3471