

RELIABILITY REPORT  
FOR  
**MAX430xPA**  
PLASTIC ENCAPSULATED DEVICES

July 14, 2003

**MAXIM INTEGRATED PRODUCTS**

120 SAN GABRIEL DR.

SUNNYVALE, CA 94086

Written by



Jim Pedicord  
Quality Assurance  
Reliability Lab Manager

Reviewed by



Bryan J. Preeshl  
Quality Assurance  
Executive Director

## Conclusion

The MAX430 successfully meets the quality and reliability standards required of all Maxim products. In addition, Maxim's continuous reliability monitoring program ensures that all outgoing product will continue to meet Maxim's quality and reliability standards.

## Table of Contents

I. ....Device Description	V. ....Quality Assurance Information
II. ....Manufacturing Information	VI. ....Reliability Evaluation
III. ....Packaging Information	
IV. ....Die Information	.....Attachments

### I. Device Description

#### A. General

The MAX430 is a CMOS +/-15V chopper-stabilized amplifier designed for high accuracy signal conditions, amplification and instrumentation applications. It offers input offset and drift specifications superior to "precision" bipolar op amps and monolithic chopper amplifiers. External capacitors, required with previous CMOS chopper amplifiers, are not needed with the MAX430. The amplifier is packaged in a 8-pin plastic DIP.

The combination of +/-15V operation, low-power, and standard op-amp configuration allows this device to plug into almost any OP07/OP77/LM108/uA741 socket regardless of what offset balancing or frequency compensation circuitry might be present. A wide input voltage range that includes the negative supply allows applications not possible with most conventional operational amplifier.

The MAX430 has a maximum supply current of 2mA and a unit gain frequency of 500kHz.

#### B. Absolute Maximum Ratings

<u>Item</u>	<u>Rating</u>
Total Supply Voltage (V+ to V-)	36V
Input Voltage	(V- + 0.3) to (V- -0.3)V
Current Into Any Pin	10mA
Duration of Output Short Circuit	Indefinite
Storage Temp.	-65°C to +160°C
Operating Temperature Range	
MAX430C	0°C to +70°C
MAX430E	-40°C to +85°C
Lead Temp. (10 sec.)	+300°C

## II. Manufacturing Information

A. Description/Function:	+/-15 Volt Chopper Stabilized Operational Amplifier
B. Process:	SMG (M6-Standard 6 micron metal gate CMOS)
C. Number of Device Transistors:	178
D. Fabrication Location:	Oregon, USA
E. Assembly Location:	Philippines
F. Date of Initial Production:	September, 1994

## III. Packaging Information

A. Package Type:	<b>8-Lead PDIP</b>
B. Lead Frame:	Copper
C. Lead Finish:	Solder Plate
D. Die Attach:	Silver-filled Epoxy
E. Bondwire:	Gold (1.0 mil dia.)
F. Mold Material:	Epoxy with silica filler
G. Assembly Diagram:	# 31-2530
H. Flammability Rating:	Class UL94-V0
I. Classification of Moisture Sensitivity per JEDEC standard JESD22-112:	Level 1

## IV. Die Information

A. Dimensions:	98 x 111 mils
B. Passivation:	SiN/SiO (nitride/oxide)
C. Interconnect:	Aluminum/Si (Si = 1%)
D. Backside Metallization:	None
E. Minimum Metal Width:	6 microns (as drawn)
F. Minimum Metal Spacing:	6 microns (as drawn)
G. Bondpad Dimensions:	5 mil. Sq.
H. Isolation Dielectric:	SiO <sub>2</sub>
I. Die Separation Method:	Wafer Saw

## V. Quality Assurance Information

- A. Quality Assurance Contacts: Jim Pedicord (Manager, Reliability Operations)  
Bryan Preeshl (Executive Director)  
Kenneth Huening (Vice President)
- B. Outgoing Inspection Level: 0.1% for all electrical parameters guaranteed by the Datasheet.  
0.1% For all Visual Defects.
- C. Observed Outgoing Defect Rate: < 50 ppm
- D. Sampling Plan: Mil-Std-105D

## VI. Reliability Evaluation

### A. Accelerated Life Test

The results of the 135°C biased (static) life test are shown in **Table 1**. Using these results, the Failure Rate ( $\lambda$ ) is calculated as follows:

$$\lambda = \frac{1}{\text{MTTF}} = \frac{1.83}{192 \times 4389 \times 545 \times 2} \quad (\text{Chi square value for MTTF upper limit})$$

▲  
Temperature Acceleration factor assuming an activation energy of 0.8eV

$$\lambda = 1.99 \times 10^{-9}$$

$$\lambda = 1.99 \text{ F.I.T. (60\% confidence level @ 25°C)}$$

This low failure rate represents data collected from Maxim's reliability monitor program. In addition to routine production Burn-In, Maxim pulls a sample from every fabrication process three times per week and subjects it to an extended Burn-In prior to shipment to ensure its reliability. The reliability control level for each lot to be shipped as standard product is 59 F.I.T. at a 60% confidence level, which equates to 3 failures in an 80 piece sample. Maxim performs failure analysis on any lot that exceeds this reliability control level. Attached Burn-In Schematic (Spec. # 06-0268) shows the static Burn-In circuit. Maxim also performs quarterly 1000 hour life test monitors. This data is published in the Product Reliability Report (**RR-1M**).

### B. Moisture Resistance Tests

Maxim pulls pressure pot samples from every assembly process three times per week. Each lot sample must meet an LTPD = 20 or less before shipment as standard product. Additionally, the industry standard 85°C/85%RH testing is done per generic device/package family once a quarter.

### C. E.S.D. and Latch-Up Testing

The OA14 die type has been found to have all pins able to withstand a transient pulse of  $\pm 2000\text{V}$ , per Mil-Std-883 Method 3015 (reference attached ESD Test Circuit). Latch-Up testing has shown that this device withstands a current of  $\pm 100\text{mA}$ .

**Table 1**  
Reliability Evaluation Test Results

**MAX430xPA**

TEST ITEM	TEST CONDITION	FAILURE IDENTIFICATION	PACKAGE	SAMPLE SIZE	NUMBER OF FAILURES
<b>Static Life Test</b> (Note 1)					
	Ta = 135°C Biased Time = 192 hrs.	DC Parameters & functionality		545	0
<b>Moisture Testing</b> (Note 2)					
Pressure Pot	Ta = 121°C P = 15 psi. RH= 100% Time = 168hrs.	DC Parameters & functionality	PDIP	77	0
85/85	Ta = 85°C RH = 85% Biased Time = 1000hrs.	DC Parameters & functionality		77	0
<b>Mechanical Stress</b> (Note 2)					
Temperature Cycle	-65°C/150°C 1000 Cycles Method 1010	DC Parameters & functionality		77	0

Note 1: Life Test Data may represent plastic DIP qualification lots.

Note 2: Generic Package/Process data

Attachment #1

TABLE II. Pin combination to be tested. 1/ 2/

	Terminal A (Each pin individually connected to terminal A with the other floating)	Terminal B (The common combination of all like-named pins connected to terminal B)
1.	All pins except $V_{PS1}$ <u>3/</u>	All $V_{PS1}$ pins
2.	All input and output pins	All other input-output pins

1/ Table II is restated in narrative form in 3.4 below.

2/ No connects are not to be tested.

3/ Repeat pin combination I for each named Power supply and for ground

(e.g., where  $V_{PS1}$  is  $V_{DD}$ ,  $V_{CC}$ ,  $V_{SS}$ ,  $V_{BB}$ , GND,  $+V_S$ ,  $-V_S$ ,  $V_{REF}$ , etc).

3.4 Pin combinations to be tested.

- a. Each pin individually connected to terminal A with respect to the device ground pin(s) connected to terminal B. All pins except the one being tested and the ground pin(s) shall be open.
- b. Each pin individually connected to terminal A with respect to each different set of a combination of all named power supply pins (e.g.,  $V_{SS1}$ , or  $V_{SS2}$  or  $V_{SS3}$  or  $V_{CC1}$ , or  $V_{CC2}$ ) connected to terminal B. All pins except the one being tested and the power supply pin or set of pins shall be open.
- c. Each input and each output individually connected to terminal A with respect to a combination of all the other input and output pins connected to terminal B. All pins except the input or output pin being tested and the combination of all the other input and output pins shall be open.

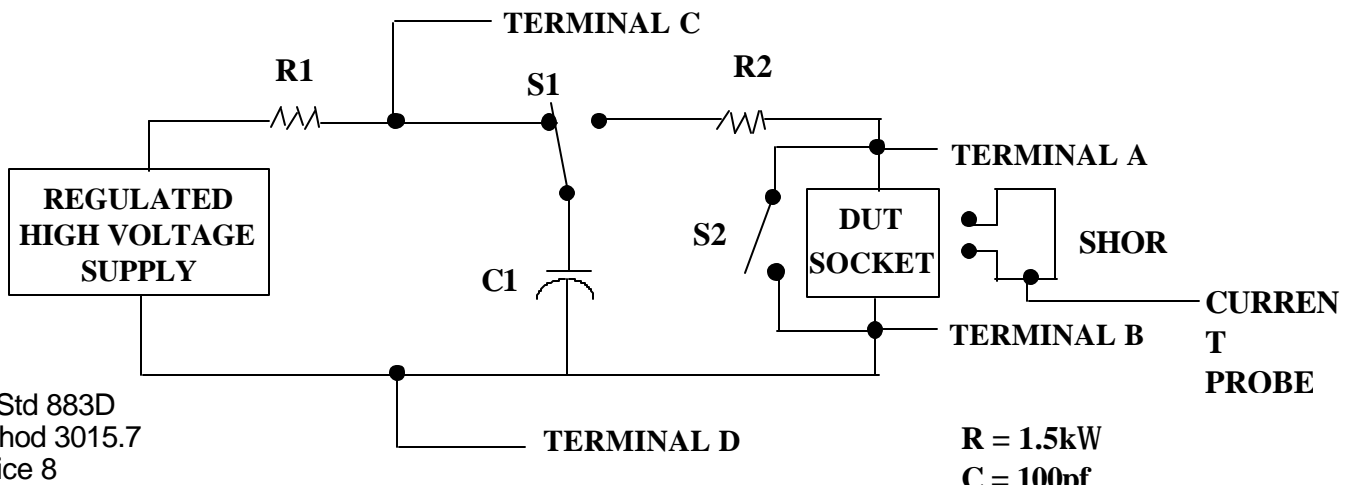

ONCE PER BOARD

ONCE PER SOCKET

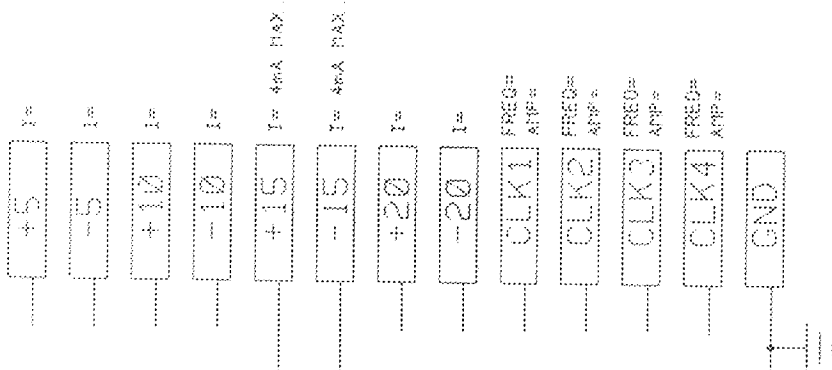

- STEADY STATE LIFE TEST IS PER MIL-STD-883 METHOD 1005.  
 - BURN-IN IS PER MIL-STD-883 METHOD 1015, COND. B

<p>NOTES:</p> <ol style="list-style-type: none"> <li>TEMPERATURE: 100°C OR EQUIVALENT</li> <li>TIME: 168 HOURS MIN. OR EQUIVALENT</li> <li>ALL COMPONENTS AND MATERIAL MUST STAND 100°C CONTINUOUS</li> <li>APPROVED FOR DX1 COMMERCIAL            DN: HR/893</li> </ol>	<p>SPEC. NO. 06-268 REV. A</p>	<p>MAXIM BURN-IN SCHEMATIC</p>
<p>DATE: 4/3/92</p>	<p>DEVICE TYPE:            LT1801, MAX400/20/22/28/32/80            OP07/27/37/50</p>	
<p>DRAWN BY: N.K. NGUYEN</p>		