

RELIABILITY REPORT
FOR
MAX3967AETG
PLASTIC ENCAPSULATED DEVICES

April 28, 2006

MAXIM INTEGRATED PRODUCTS

120 SAN GABRIEL DR.

SUNNYVALE, CA 94086

Written by

Jim Pedicord
Quality Assurance
Manager, Reliability Operations

Conclusion

The MAX3967A successfully meets the quality and reliability standards required of all Maxim products. In addition, Maxim's continuous reliability monitoring program ensures that all outgoing product will continue to meet Maxim's quality and reliability standards.

Table of Contents

I.Device Description	V.Quality Assurance Information
II.Manufacturing Information	VI.Reliability Evaluation
III.Packaging Information	
IV.Die InformationAttachments

I. Device Description

A. General

The MAX3967A is a programmable LED driver for fiber optic transmitters operating at data rates up to 270Mbps. The circuit contains a high-speed current driver with programmable temperature coefficient (tempco), adjustments for LED prebias voltage, and a disable feature. The circuit accepts PECL data inputs, and operates from a single +2.97V to +5.5V power supply.

The SFP LED driver can switch up to 100mA into typical high-speed light-emitting diodes. As temperature increases, the device's modulation current increases with a tempco that is programmable from 2500ppm/°C to 12,000ppm/°C. The modulation current is programmed with a single external resistor.

The MAX3967A's LED prebias voltage is programmable from 400mV to 925mV. The prebias circuit produces peaking current, which improves the LED switching speed.

Complementary current outputs help to maintain a constant supply current, reducing EMI and supply noise generated by the transmitter module. The MAX3967A is available in die form, or in a 4mm x 4mm, 24-pin thin QFN package.

B. Absolute Maximum Ratings

<u>Item</u>	<u>Rating</u>
Supply Voltage at VCC, VCCOUT (VEE, VEEOUT = 0V)	-0.5V to +7V
Current into OUT+, OUT-	-40mA to +160mA
Differential Output Voltage (OUT+ to OUT-)	-3.3V to +3.3V
Voltage at PB1, PB2, PB3, IN+, IN-, OUT+, OUT-, TX_DISABLE	-0.5V to (VCC + 0.5V)
Voltage at TCMIN, TCNOM, TC, MODSET, MON	-0.5V to +2V
Continuous Power Dissipation (TA = +85°C) 24-Lead Thin QFN (derate 20.8mW/C°above +85°C)	1354mW
Operating Junction Temperature Range	-40°C to +150°C
Die Attach Temperature.	+375°C
Storage Temperature Range	-50°C to +150°C
Lead Temperature (soldering, 10s)	+300°C

II. Manufacturing Information

A. Description/Function:	270Mbps SFP LED Driver
B. Process:	CB20 (Complementary Bipolar Process)
C. Number of Device Transistors:	331
D. Fabrication Location:	Oregon, USA
E. Assembly Location:	Thailand
F. Date of Initial Production:	April, 2005

III. Packaging Information

A. Package Type:	24-Lead Thin QFN
B. Lead Frame:	Copper
C. Lead Finish:	Solder Plate or 100% Matte Tin
D. Die Attach:	Silver-Filled Epoxy
E. Bondwire:	Gold (1 mil dia.)
F. Mold Material:	Epoxy with silica filler
G. Assembly Diagram:	# 05-9000-1710
H. Flammability Rating:	Class UL94-V0
I. Classification of Moisture Sensitivity per JEDEC standard J-STD-020-C:	Level 1

IV. Die Information

A. Dimensions:	48 x 73 mils
B. Passivation:	Si ₃ N ₄ /SiO ₂ (Silicon nitride/ Silicon dioxide)
C. Interconnect:	Gold
D. Backside Metallization:	None
E. Minimum Metal Width:	2 microns (as drawn)
F. Minimum Metal Spacing:	2 microns (as drawn)
G. Bondpad Dimensions:	5 mil. Sq.
H. Isolation Dielectric:	SiO ₂
I. Die Separation Method:	Wafer Saw

V. Quality Assurance Information

A. Quality Assurance Contacts:

Jim Pedicord (Manager, Reliability Operations)
Bryan Preeshl (Managing Director of QA)

B. Outgoing Inspection Level: 0.1% for all electrical parameters guaranteed by the Datasheet.
0.1% For all Visual Defects.

C. Observed Outgoing Defect Rate: < 50 ppm

D. Sampling Plan: Mil-Std-105D

VI. Reliability Evaluation

A. Accelerated Life Test

The results of the 150°C biased (static) life test are shown in **Table 1**. Using these results, the Failure Rate (λ) is calculated as follows:

$$\lambda = \frac{1}{\text{MTTF}} = \frac{1.83}{192 \times 9706 \times 48 \times 2} \quad (\text{Chi square value for MTTF upper limit})$$

↳ Thermal acceleration factor assuming a 0.8eV activation energy

$$\lambda = 10.24 \times 10^{-9}$$

$$\lambda = 10.24 \text{ F.I.T. (60\% confidence level @ 25°C)}$$

This low failure rate represents data collected from Maxim's reliability qualification and monitor programs. Maxim also performs weekly Burn-In on samples from production to assure the reliability of its processes. The reliability required for lots which receive a burn-in qualification is 59 F.I.T. at a 60% confidence level, which equates to 3 failures in an 80 piece sample. Maxim performs failure analysis on lots exceeding this level. The following Burn-In Schematic (Spec. # 06-7226) shows the static circuit used for this test. Maxim also performs 1000 hour life test monitors quarterly for each process. This data is published in the Product Reliability Report (**RR-B3A**). Current monitor data for the CB20 Process results in a FIT Rate of 0.17 @ 25C and 2.86 @ 55C (0.8 eV, 60% UCL)

B. Moisture Resistance Tests

Maxim evaluates pressure pot stress from every assembly process during qualification of each new design. Pressure Pot testing must pass a 20% LTPD for acceptance. Additionally, industry standard 85°C/85%RH or HAST tests are performed quarterly per device/package family.

C. E.S.D. and Latch-Up Testing

The HD81 die type has been found to have all pins able to withstand a transient pulse of $\pm 2000\text{V}$, per Mil-Std-883 Method 3015 (reference attached ESD Test Circuit). Latch-Up testing has shown that this device withstands a current of $\pm 250\text{mA}$.

Table 1
Reliability Evaluation Test Results

MAX3967AETG

TEST ITEM	TEST CONDITION	FAILURE IDENTIFICATION	SAMPLE SIZE	NUMBER OF FAILURES
Static Life Test (Note 1)				
	Ta = 150°C Biased Time = 192 hrs.	DC Parameters & functionality	48	0
Moisture Testing (Note 2)				
Pressure Pot	Ta = 121°C P = 15 psi. RH= 100% Time = 168hrs.	DC Parameters & functionality	77	0
85/85	Ta = 85°C RH = 85% Biased Time = 1000hrs.	DC Parameters & functionality	77	0
Mechanical Stress (Note 2)				
Temperature Cycle	-65°C/150°C 1000 Cycles Method 1010	DC Parameters & functionality	77	0

Note 1: Life Test Data may represent plastic D.I.P. qualification lots.

Note 2: Generic Package/Process data

Attachment #1

TABLE II. Pin combination to be tested. 1/ 2/

	Terminal A (Each pin individually connected to terminal A with the other floating)	Terminal B (The common combination of all like-named pins connected to terminal B)
1.	All pins except V_{PS1} <u>3/</u>	All V_{PS1} pins
2.	All input and output pins	All other input-output pins

1/ Table II is restated in narrative form in 3.4 below.

2/ No connects are not to be tested.

3/ Repeat pin combination I for each named Power supply and for ground

(e.g., where V_{PS1} is V_{DD} , V_{CC} , V_{SS} , V_{BB} , GND, $+V_S$, $-V_S$, V_{REF} , etc).

3.4 Pin combinations to be tested.

- a. Each pin individually connected to terminal A with respect to the device ground pin(s) connected to terminal B. All pins except the one being tested and the ground pin(s) shall be open.
- b. Each pin individually connected to terminal A with respect to each different set of a combination of all named power supply pins (e.g., V_{SS1} , or V_{SS2} or V_{SS3} or V_{CC1} , or V_{CC2}) connected to terminal B. All pins except the one being tested and the power supply pin or set of pins shall be open.
- c. Each input and each output individually connected to terminal A with respect to a combination of all the other input and output pins connected to terminal B. All pins except the input or output pin being tested and the combination of all the other input and output pins shall be open.

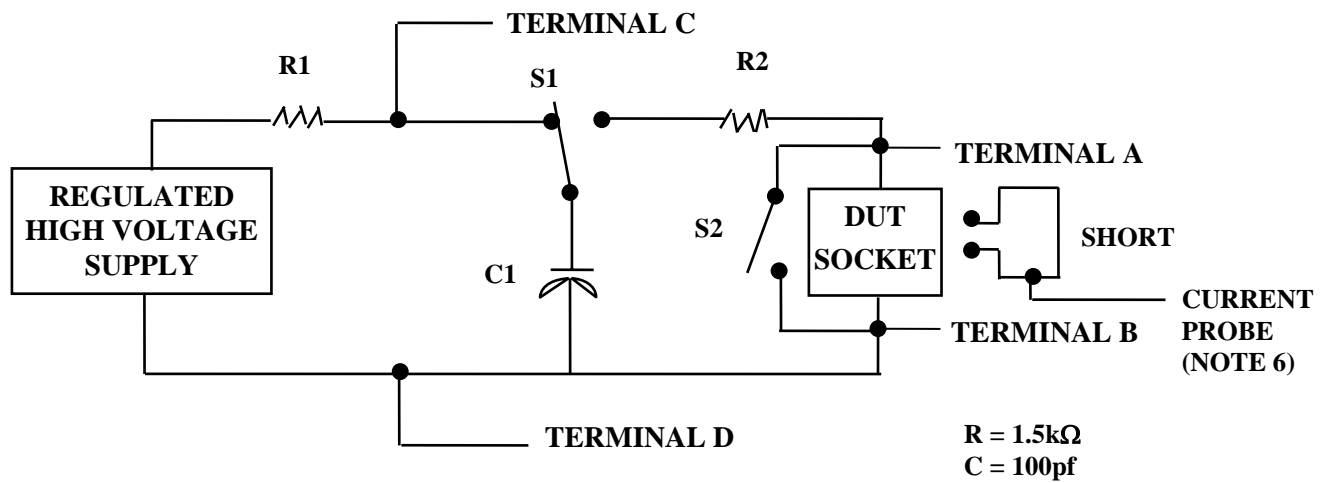

4x4x0.8mm THIN QFN PKG.

EXPOSED PAD PKG.

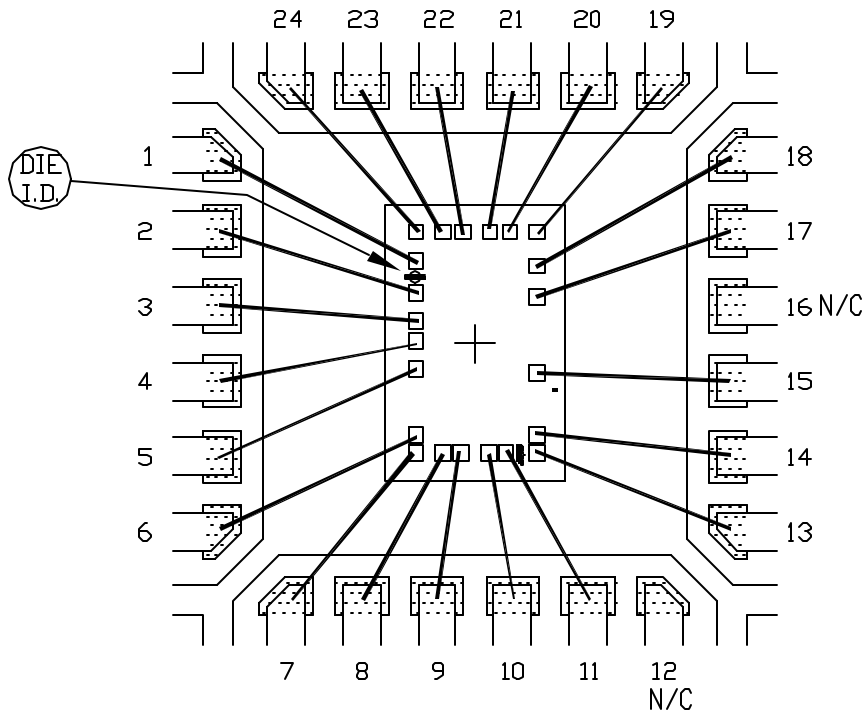

 BONDABLE AREA

PKG. CODE: T2444-4		SIGNATURES	DATE	 CONFIDENTIAL & PROPRIETARY	
CAV./PAD SIZE: 110x110	PKG. DESIGN			BOND DIAGRAM #: 05-9000-1710	REV: A

