

RELIABILITY REPORT
FOR
MAX1602EEE
PLASTIC ENCAPSULATED DEVICES

April 24, 2003

MAXIM INTEGRATED PRODUCTS

120 SAN GABRIEL DR.
SUNNYVALE, CA 94086

Written by



Jim Pedicord
Quality Assurance
Reliability Lab Manager

Reviewed by



Bryan J. Preeshl
Quality Assurance
Executive Director

Conclusion

The MAX1602 successfully meets the quality and reliability standards required of all Maxim products. In addition, Maxim's continuous reliability monitoring program ensures that all outgoing product will continue to meet Maxim's quality and reliability standards.

Table of Contents

I.Device Description	V.Quality Assurance Information
II.Manufacturing Information	VI.Reliability Evaluation
III.Packaging Information	
IV.Die InformationAttachments

I. Device Description

A. General

The MAX1602 DC power-switching IC contains a network of low-resistance MOSFET switches that deliver selectable V_{CC} and V_{PP} voltages to a single CardBus or PC Card host socket. Key features include low-resistance switches, small packaging, soft-switching action, and compliance with PCMCIA specifications for 3V/5V switching. 3.3V-only power switching for fast, 32-bit CardBus applications is supported in two ways: low-resistance 3.3V switches allow high 3.3V load currents (up to 1A); and completely independent internal charge pumps let the 3.3V switch operate normally, even if the +5V and +12V supplies are disconnected or turned off to conserve power. The internal charge pumps are regulating types that draw reduced input current when the V_{CC} switches are static. Also, power consumption is automatically reduces to 11 μ A max when the outputs are high-Z or GND.

Other key features include guaranteed specifications for output current limit level, and guaranteed specifications for output rise/fall times (in compliance with PCMCIA specifications). Reliability is enhanced by thermal-overload protection, accurate current limiting, an overcurrent-fault flag output, and undervoltage lockouts. The CMOS/TTL-logic interface is flexible, and can tolerate logic input levels in excess of the positive supply rail.

B. Absolute Maximum Ratings

<u>Item</u>	<u>Rating</u>
Inputs/Outputs to GND (V_X , V_Y , V_{CC}) (Note 1)	-0.3V, +6V
V_{PP} Inputs/Outputs to GND (12IN, V_{PP}) (Note 1)	-0.3V, +15V
Logic Inputs to GND ($A0V_{CC}$, $A1V_{CC}$, $A0V_{PP}$, $A1V_{PP}$) (Note 1)	-0.3V, +6V
CODE Input to GND	-0.3V, ($V_Y + 0.3V$)
V_{CC} Output Current (Note 2)	4A
V_{PP} Output Current (Note 2)	260mA
V_{CC} Short Circuit to GND	Continuous
V_{PP} Short Circuit to GND	Continuous
Storage Temp.	-65°C to +160°C
Lead Temp. (10 sec.)	+300°C
Operating Temperature Range	-40°C to +85°C
Continuous Power Dissipation ($T_A = +70^\circ\text{C}$)	
16-Pin QSOP	667mW
Derates above +70°C	
16-Pin QSOP	8.3mW/°C

Note 1: There are no parasitic diodes between any of these pins, so there are no power-up sequencing restrictions (for example, logic input signals can be applied even if all of the supply voltage inputs are grounded).

Note 2 V_{CC} and V_{PP} outputs are internally current-limited. See the Electrical Characteristics on the MAX1602 Data Sheet.

II. Manufacturing Information

A. Description/Function:	Single-Channel CardBus and PCMCIA V_{CC}/V_{PP} Power-Switching Network
B. Process:	S12 - Standard 1.2 micron silicon gate CMOS)
C. Number of Device Transistors:	1452
D. Fabrication Location:	Oregon or California, USA
E. Assembly Location:	Korea, Philippines, Thailand, or Malaysia
F. Date of Initial Production:	September, 1996

III. Packaging Information

A. Package Type:	16-Lead QSOP
B. Lead Frame:	Copper
C. Lead Finish:	Solder Plate
D. Die Attach:	Silver-filled Epoxy
E. Bondwire:	Gold (1.3 mil dia.)
F. Mold Material:	Epoxy with silica filler
G. Assembly Diagram:	# 05-1701-0305
H. Flammability Rating:	Class UL94-V0
I. Classification of Moisture Sensitivity per JEDEC standard JESD22-A112:	Level 1

IV. Die Information

A. Dimensions:	86 x 120 mils
B. Passivation:	$\text{Si}_3\text{N}_4/\text{SiO}_2$ (Silicon nitride/ Silicon dioxide)
C. Interconnect:	TiW/ AlCu/ TiWN
D. Backside Metallization:	None
E. Minimum Metal Width:	1.2 microns (as drawn)
F. Minimum Metal Spacing:	1.2 microns (as drawn)
G. Bondpad Dimensions:	5 mil. Sq.
H. Isolation Dielectric:	SiO_2
I. Die Separation Method:	Wafer Saw

V. Quality Assurance Information

A. Quality Assurance Contacts:

Jim Pedicord (Manager, Reliability Operations)
Bryan Preeshl (Executive Director of QA)
Kenneth Huening (Vice President)

B. Outgoing Inspection Level: 0.1% for all electrical parameters guaranteed by the Datasheet.
0.1% For all Visual Defects.

C. Observed Outgoing Defect Rate: < 50 ppm

D. Sampling Plan: Mil-Std-105D

VI. Reliability Evaluation

A. Accelerated Life Test

The results of the 135°C biased (static) life test are shown in **Table 1**. Using these results, the Failure Rate (λ) is calculated as follows:

$$\lambda = \frac{1}{\text{MTTF}} = \frac{1.83}{192 \times 4389 \times 100 \times 2} \quad (\text{Chi square value for MTTF upper limit})$$

└ Thermal acceleration factor assuming a 0.8eV activation energy

$$\lambda = 10.86 \times 10^{-9} \quad \lambda = 10.86 \text{ F.I.T. (60\% confidence level @ 25°C)}$$

This low failure rate represents data collected from Maxim's reliability qualification and monitor programs. Maxim also performs weekly Burn-In on samples from production to assure the reliability of its processes. The reliability required for lots which receive a burn-in qualification is 59 F.I.T. at a 60% confidence level, which equates to 3 failures in an 80 piece sample. Maxim performs failure analysis on lots exceeding this level. The following Burn-In Schematic (Spec. # 06-5205) shows the static circuit used for this test. Maxim also performs 1000 hour life test monitors quarterly for each process. This data is published in the Product Reliability Report (**RR-1K**).

B. Moisture Resistance Tests

Maxim evaluates pressure pot stress from every assembly process during qualification of each new design. Pressure Pot testing must pass a 20% LTPD for acceptance. Additionally, industry standard 85°C/85%RH or HAST tests are performed quarterly per device/package family.

C. E.S.D. and Latch-Up Testing

The PW59 die type has been found to have all pins able to withstand a transient pulse of $\pm 600\text{V}$, per Mil-Std-883 Method 3015 (reference attached ESD Test Circuit). Latch-Up testing has shown that this device withstands a current of $\pm 250\text{mA}$.

Table 1
Reliability Evaluation Test Results

MAX1602EEE

TEST ITEM	TEST CONDITION	FAILURE IDENTIFICATION	SAMPLE SIZE	NUMBER OF FAILURES
Static Life Test (Note 1)				
	Ta = 135°C Biased Time = 192 hrs.	DC Parameters & functionality	100	0
Moisture Testing (Note 2)				
Pressure Pot	Ta = 121°C P = 15 psi. RH= 100% Time = 168hrs.	DC Parameters & functionality	77	0
85/85	Ta = 85°C RH = 85% Biased Time = 1000hrs.	DC Parameters & functionality	77	0
Mechanical Stress (Note 2)				
Temperature Cycle	-65°C/150°C 1000 Cycles Method 1010	DC Parameters & functionality	77	0

Note 1: Life Test Data may represent plastic D.I.P. qualification lots.

Note 2: Generic Package/Process data

Attachment #1

TABLE II. Pin combination to be tested. 1/ 2/

	Terminal A (Each pin individually connected to terminal A with the other floating)	Terminal B (The common combination of all like-named pins connected to terminal B)
1.	All pins except V_{PS1} 3/	All V_{PS1} pins
2.	All input and output pins	All other input-output pins

1/ Table II is restated in narrative form in 3.4 below.

2/ No connects are not to be tested.

3/ Repeat pin combination I for each named Power supply and for ground

(e.g., where V_{PS1} is V_{DD} , V_{CC} , V_{SS} , V_{BB} , GND, $+V_S$, $-V_S$, V_{REF} , etc).

3.4 Pin combinations to be tested.

- a. Each pin individually connected to terminal A with respect to the device ground pin(s) connected to terminal B. All pins except the one being tested and the ground pin(s) shall be open.
- b. Each pin individually connected to terminal A with respect to each different set of a combination of all named power supply pins (e.g., V_{SS1} , or V_{SS2} or V_{SS3} or V_{CC1} , or V_{CC2}) connected to terminal B. All pins except the one being tested and the power supply pin or set of pins shall be open.
- c. Each input and each output individually connected to terminal A with respect to a combination of all the other input and output pins connected to terminal B. All pins except the input or output pin being tested and the combination of all the other input and output pins shall be open.

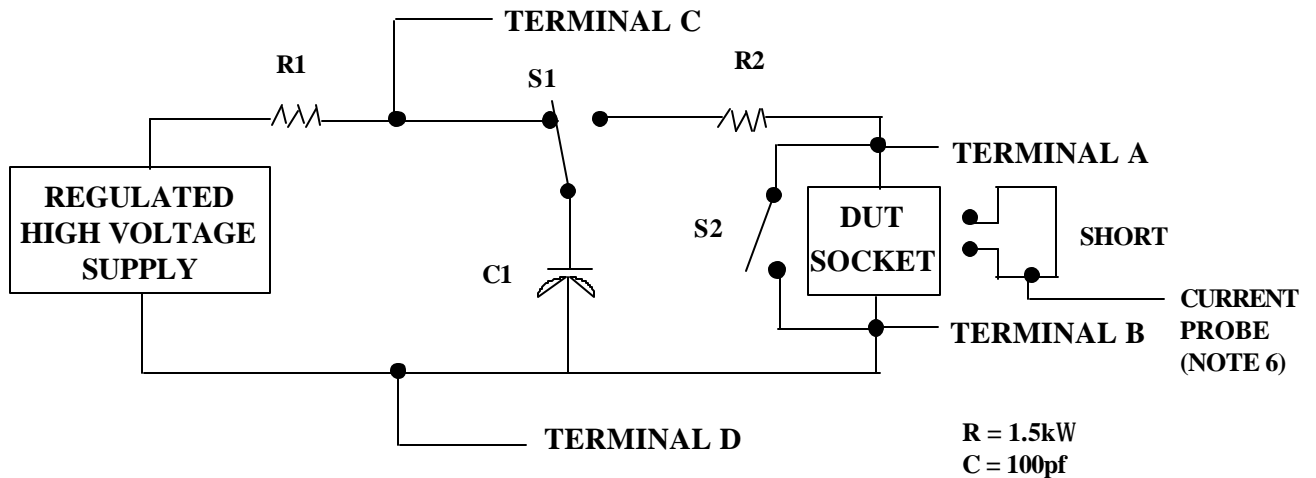

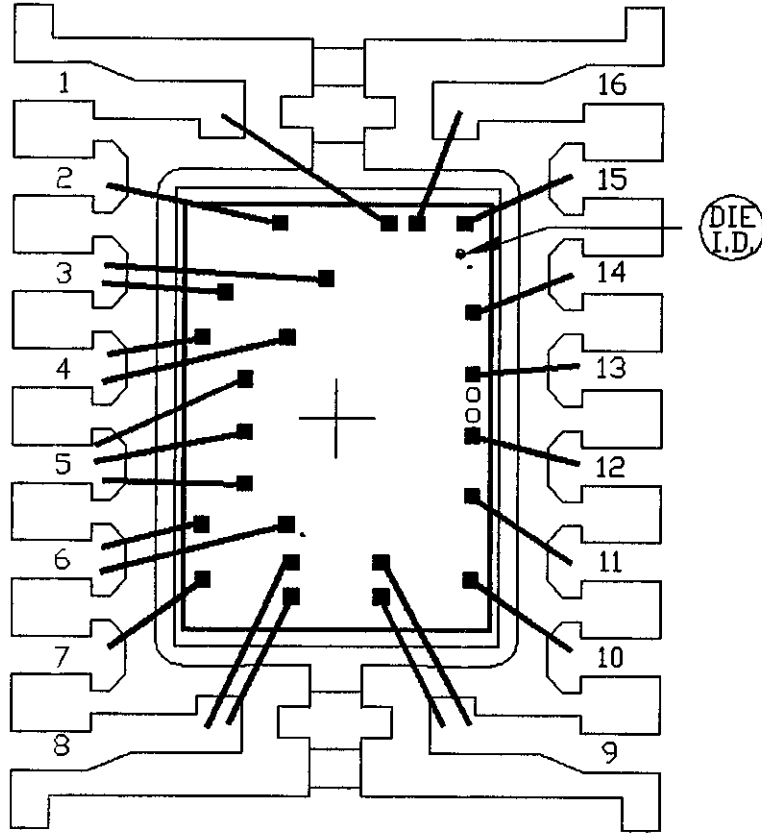

PKG. CODE: E16-1		APPROVALS	DATE	MAXIM	
CAV./PAD SIZE: 96X130	PKG. DESIGN			BUILDSHEET NUMBER: 05-1701-0305	REV.: A

ONCE PER BOARD

ONCE PER DEVICE

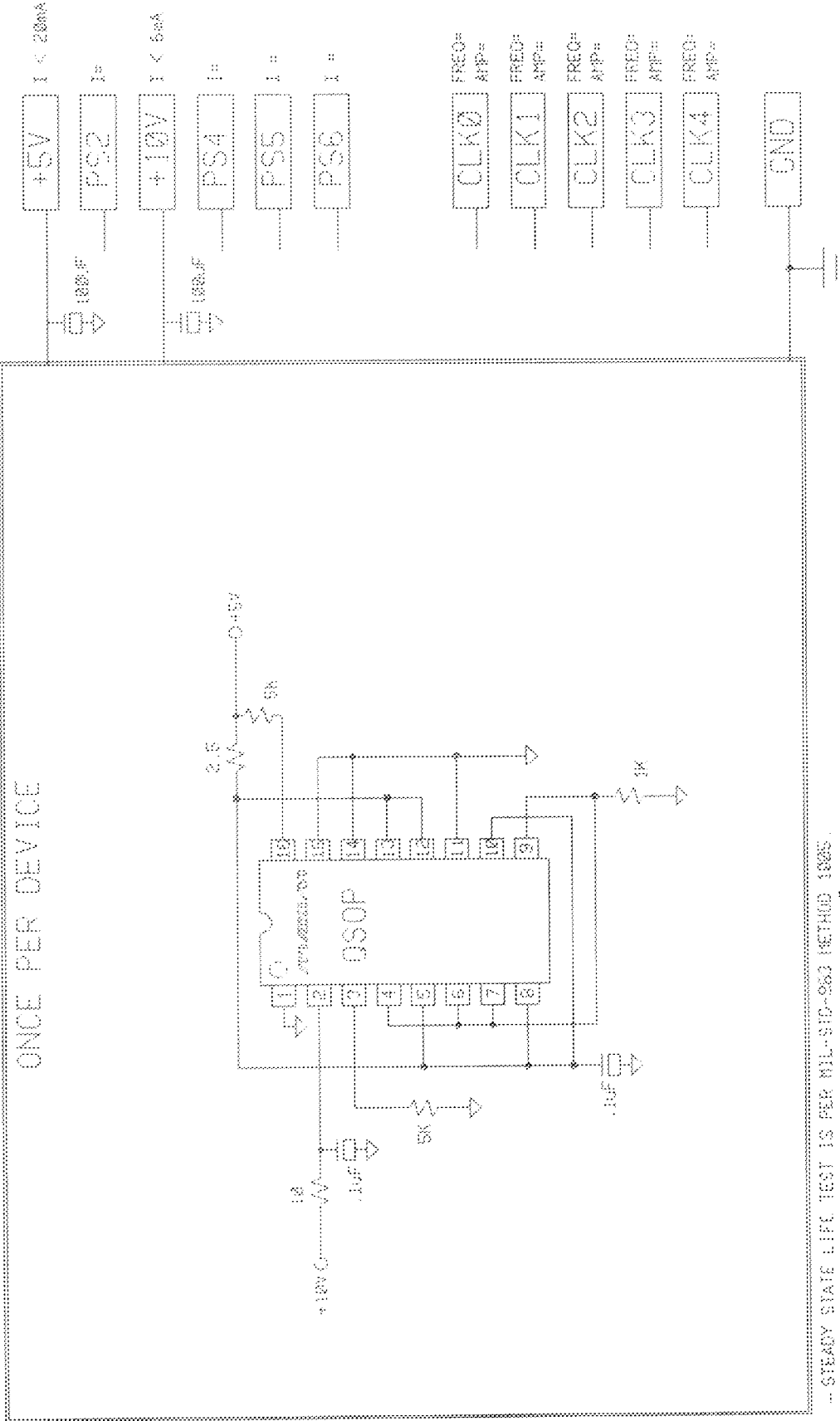

— STEADY STATE LIFE TEST IS PER MIL-STD-883 METHOD 1005.
 — BURN-IN IS PER MIL-STD-883 METHOD 1015. C000. B

NOTES :

1. TEMPERATURE : 125C OR EQUIVALENT
2. TIME : 168 HOURS MIN. OR EQUIVALENT
3. ALL COMPONENTS AND MATERIAL MUST STAND 155C CONTINUOUS
4. APPROVED FOR (X) COMMERCIAL (X) 182/880

SPEC. NO. 06-5205 REV: B

MAXIM BURN-IN SCHEMATIC

DATE: 7\09\96

DEVICE TYPE(S):

DRAWN BY: R. TARIQA

MAX1602