

RELIABILITY REPORT  
FOR  
**MAX038xxP**  
PLASTIC ENCAPSULATED DEVICES

January 8, 2001

**MAXIM INTEGRATED PRODUCTS**

120 SAN GABRIEL DR.

SUNNYVALE, CA 94086

Written by



Jim Pedicord  
Quality Assurance  
Reliability Lab Manager

Reviewed by



Bryan J. Preeshl  
Quality Assurance  
Executive Director

## Conclusion

The MAX038 successfully meets the quality and reliability standards required of all Maxim products. In addition, Maxim's continuous reliability monitoring program ensures that all outgoing product will continue to meet Maxim's quality and reliability standards.

## Table of Contents

I. ....Device Description	V. ....Quality Assurance Information
II. ....Manufacturing Information	VI. ....Reliability Evaluation
III. ....Packaging Information	
IV. ....Die Information	.....Attachments

### I. Device Description

#### A. General

The MAX038 is a high-frequency, precision function generator producing accurate, high-frequency triangle, sawtooth, sine, square, and pulse waveforms with a minimum of external components. The output frequency can be controlled over a frequency range of 0.1Hz to 20 Mhz by an internal 2.5V bandgap voltage reference and an external resistor and capacitor. The duty cycle can be varied over a wide range by applying a  $\pm 2.3V$  control signal, facilitating pulse-width modulation and the generation of sawtooth waveforms. Frequency modulation and frequency sweeping are achieved in the same way. The duty cycle and frequency controls are independent.

Sine, square, or triangle waveforms can be selected at the output by setting the appropriate code at two TTL-compatible select pins. The output signal for all waveforms is a  $2V_{P-P}$  signal that is symmetrical around ground. The low-impedance output can drive up to  $\pm 20mA$ .

The TTL-compatible SYNC output from the internal oscillator maintains a 50% duty cycle - regardless of the duty cycle of the other waveforms - to synchronize other devices in the system. The internal oscillator can be synchronized to an external TTL clock connected to PDI.

#### B. Absolute Maximum Ratings

<u>Item</u>	<u>Rating</u>
V+ to GND	-0.3V to +6V
DV+ to DGND	-0.3V to +6V
V- to GND	+0.3V to -6V
Pin Voltages	
IIN, FADJ, DADJ, PDO	(V- -0.3V) to (V+ + 0.3V)
COSC	+0.3V to V-
A0, A1, PDI, SYNC, REF	-0.3V to V+
GND to DGND	$\pm 0.3V$
Maximum Current into any Pin	$\pm 50mA$
OUT, REF Short-Circuit Duration of GND, V+, V-	30 sec
Storage Temp.	-65°C to +160°C
Lead Temp. (10 sec.)	+300°C
Power Dissipation	
PDIP	889mW
WSO	800mW
Derates above +70°C	
PDIP	11.11mW/°C
WSO	10.00mW/°C

## II. Manufacturing Information

A. Description/Function:	High-Frequency Waveform Generator
B. Process:	CBP (Complimentary Bipolar Process)
C. Number of Device Transistors:	855
D. Fabrication Location:	California, USA
E. Assembly Location:	Philippines, Malaysia, or Korea
F. Date of Initial Production:	June, 1994

## III. Packaging Information

A. Package Type:	<b>20 Lead Dip</b>	<b>20 Lead WSO</b>
B. Lead Frame:	Copper	Copper
C. Lead Finish:	Solder Plate	Solder Plate
D. Die Attach:	Silver-filled Epoxy	Silver-filled Epoxy
E. Bondwire:	Gold (1.3 mil dia.)	Gold (1.3 mil dia.)
F. Mold Material:	Epoxy with silica filler	Epoxy with silica filler
G. Assembly Diagram:	Buildsheet # 05-1801-0007	Buildsheet # 05-1801-0008
H. Flammability Rating:	Class UL94-V0	Class UL94-V0

## IV. Die Information

A. Dimensions:	106x118 mils
B. Passivation:	$\text{Si}_3\text{N}_4/\text{SiO}_2$ (Silicon nitride/ Silicon dioxide)
C. Interconnect:	Aluminum/Si (Si = 1%)
D. Backside Metallization:	None
E. Minimum Metal Width:	Metal1: 6; Metal2: 8 microns (as drawn)
F. Minimum Metal Spacing:	Metal1: 2; Metal2: 3 microns (as drawn)
G. Bondpad Dimensions:	5 mil. Sq.
H. Isolation Dielectric:	$\text{SiO}_2$
I. Die Separation Method:	Wafer Saw

## V. Quality Assurance Information

- A. Quality Assurance Contacts: Jim Pedicord (Reliability Lab Manager)  
Bryan Preeshl (Executive Director)  
Kenneth Huening (Vice President)
- B. Outgoing Inspection Level: 0.1% for all electrical parameters guaranteed by the Datasheet.  
0.1% For all Visual Defects.
- C. Observed Outgoing Defect Rate: < 100 ppm
- D. Sampling Plan: Mil-Std-105D

## VI. Reliability Evaluation

### A. Accelerated Life Test

The results of the 135°C biased (static) life test are shown in **Table 1**. Using these results, the Failure Rate ( $\lambda$ ) is calculated as follows:

$$\lambda = \frac{1}{\text{MTTF}} = \frac{1.83}{192 \times 4389 \times 80 \times 2} \quad (\text{Chi square value for MTTF upper limit})$$

↓  
Temperature Acceleration factor assuming an activation energy of 0.8eV

$$\lambda = 13.57 \times 10^{-9}$$

$$\lambda = 13.57 \text{ F.I.T. (60\% confidence level @ 25°C)}$$

This low failure rate represents data collected from Maxim's reliability monitor program. In addition to routine production Burn-In, Maxim pulls a sample from every fabrication process three times per week and subjects it to an extended Burn-In prior to shipment to ensure its reliability. The reliability control level for each lot to be shipped as standard product is 59 F.I.T. at a 60% confidence level, which equates to 3 failures in an 80 piece sample. Maxim performs failure analysis on any lot that exceeds this reliability control level. Attached Burn-In Schematic (Spec. # 06-5000) shows the static Burn-In circuit. Maxim also performs quarterly 1000 hour life test monitors. This data is published in the Product Reliability Report (**RR-1M**).

### B. Moisture Resistance Tests

Maxim pulls pressure pot samples from every assembly process three times per week. Each lot sample must meet an LTPD = 20 or less before shipment as standard product. Additionally, the industry standard 85°C/85%RH testing is done per generic device/package family once a quarter.

### C. E.S.D. and Latch-Up Testing

The FGO1 die type has been found to have all pins able to withstand a transient pulse of  $\pm 1000\text{V}$ , per Mil-Std-883 Method 3015 (reference attached ESD Test Circuit). Latch-Up testing has shown that this device withstands a current of  $\pm 100\text{mA}$  and/or  $\pm 20\text{V}$ .

**Table 1**  
Reliability Evaluation Test Results

**MAX038xxP**

TEST ITEM	TEST CONDITION	FAILURE IDENTIFICATION	PACKAGE	SAMPLE SIZE	NUMBER OF FAILURES
<b>Static Life Test</b> (Note 1)					
	Ta = 135°C Biased Time = 192 hrs.	DC Parameters & functionality		800	0
<b>Moisture Testing</b> (Note 2)					
Pressure Pot	Ta = 121°C P = 15 psi. RH= 100% Time = 96hrs.	DC Parameters & functionality	PDIP WSO	77 77	0 0
85/85	Ta = 85°C RH = 85% Biased Time = 1000hrs.	DC Parameters & functionality		77	0
<b>Mechanical Stress</b> (Note 2)					
Temperature Cycle	-65°C/150°C 1000 Cycles Method 1010	DC Parameters		77	0

Note 1: Life Test Data may represent plastic D.I.P. qualification lots.

Note 2: Generic package/process data.

Attachment #1

TABLE II. Pin combination to be tested. 1/ 2/

	Terminal A (Each pin individually connected to terminal A with the other floating)	Terminal B (The common combination of all like-named pins connected to terminal B)
1.	All pins except $V_{PS1}$ 3/	All $V_{PS1}$ pins
2.	All input and output pins	All other input-output pins

1/ Table II is restated in narrative form in 3.4 below.

2/ No connects are not to be tested.

3/ Repeat pin combination I for each named Power supply and for ground (e.g., where  $V_{PS1}$  is  $V_{DD}$ ,  $V_{CC}$ ,  $V_{SS}$ ,  $V_{BB}$ , GND,  $+V_S$ ,  $-V_S$ ,  $V_{REF}$ , etc).

3.4 Pin combinations to be tested.

- a. Each pin individually connected to terminal A with respect to the device ground pin(s) connected to terminal B. All pins except the one being tested and the ground pin(s) shall be open.
- b. Each pin individually connected to terminal A with respect to each different set of a combination of all named power supply pins (e.g.,  $V_{SS1}$ , or  $V_{SS2}$  or  $V_{SS3}$  or  $V_{CC1}$ , or  $V_{CC2}$ ) connected to terminal B. All pins except the one being tested and the power supply pin or set of pins shall be open.
- c. Each input and each output individually connected to terminal A with respect to a combination of all the other input and output pins connected to terminal B. All pins except the input or output pin being tested and the combination of all the other input and output pins shall be open.

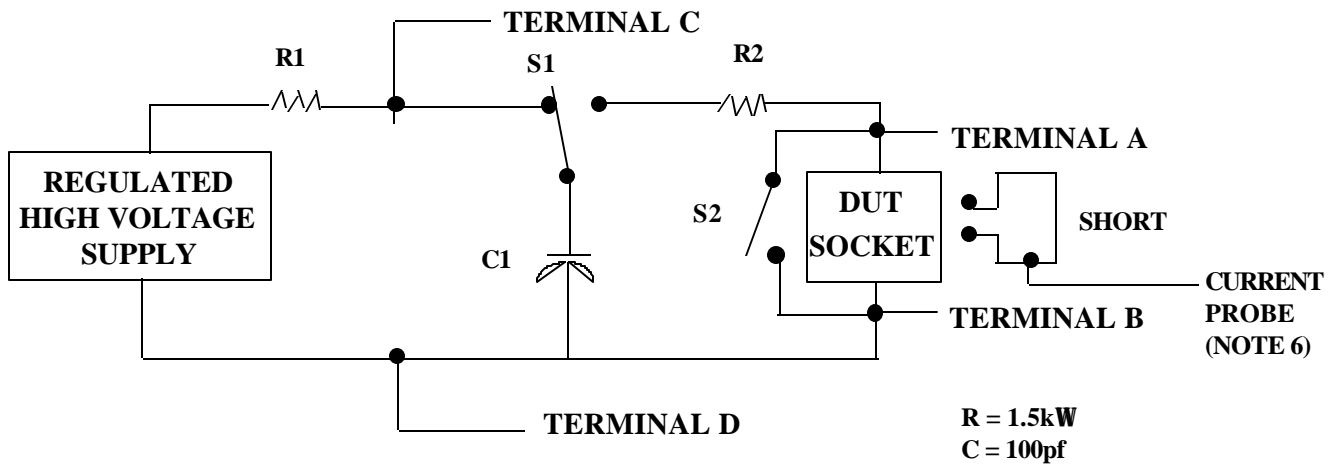

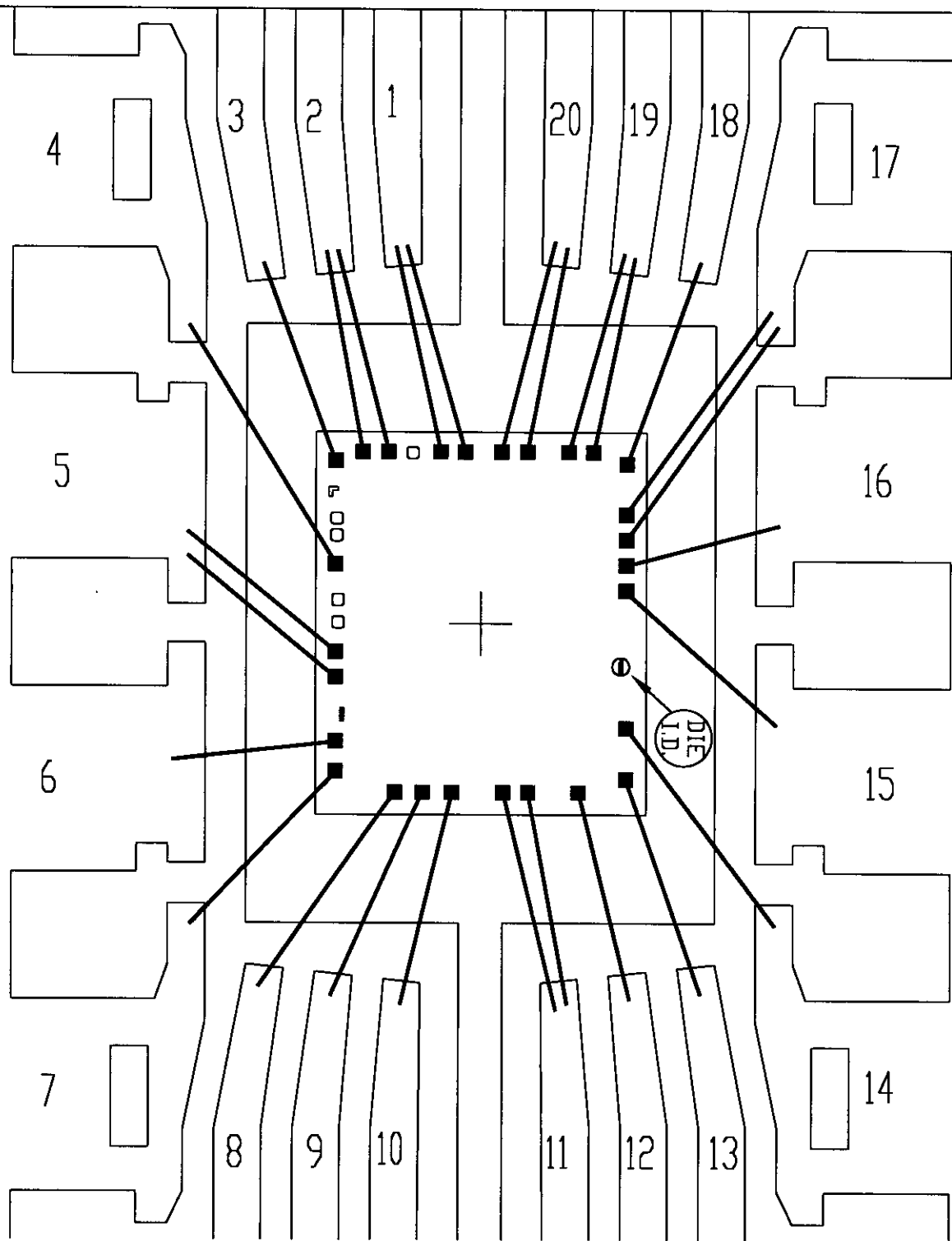

PKG.CODE: P20-3		APPROVALS	DATE	<b>MAXIM</b>
CAV./PAD SIZE: 150 X 190	PKG. DESIGN			BUILDSHEET NUMBER: 05-1801-0007
				REV.: A

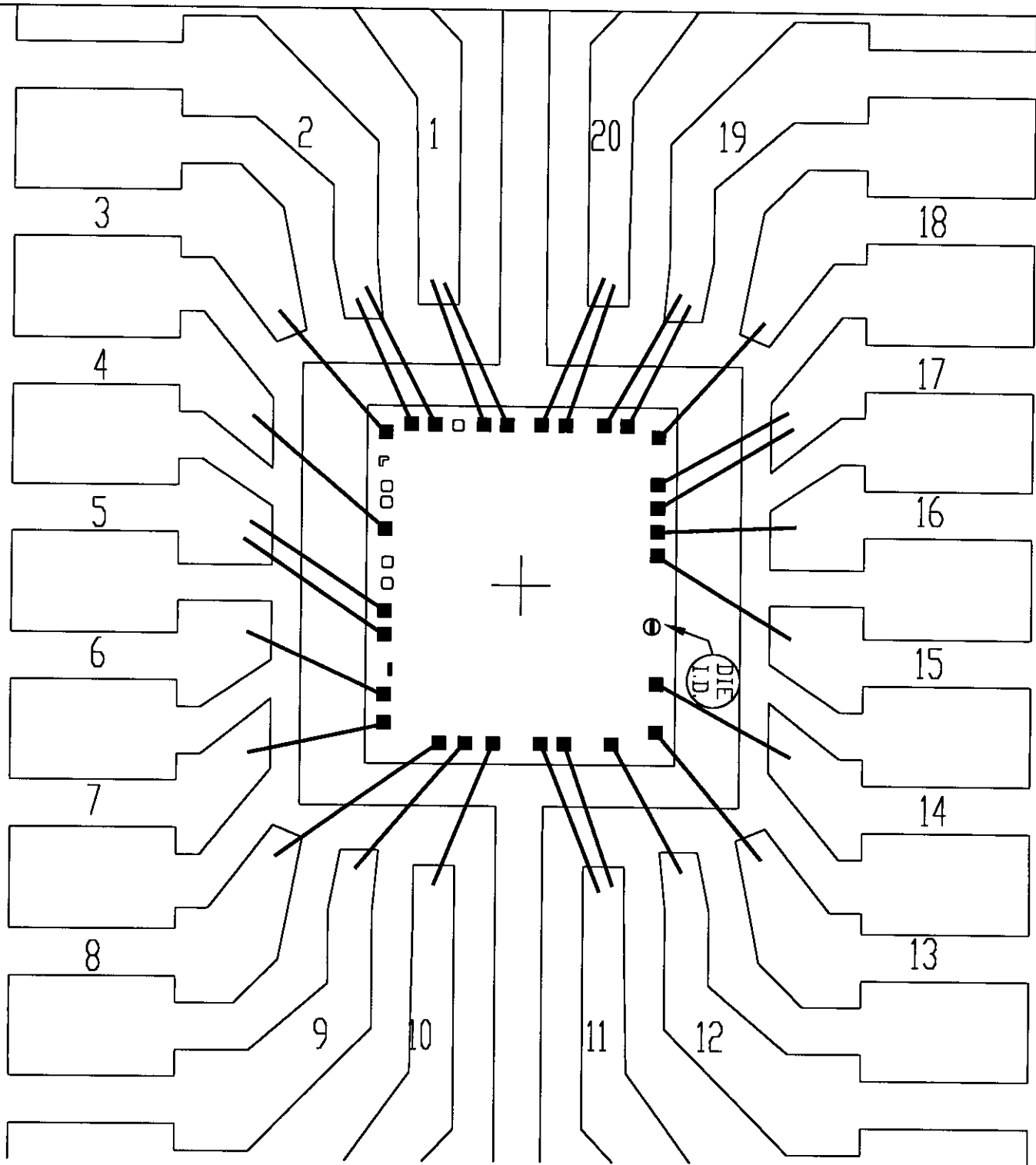

PKG.CODE: W20-2		APPROVALS	DATE	<b>MAXIM</b>	
CAV./PAD SIZE: 150 X 150	PKG. DESIGN			BUILDSHEET NUMBER: 05-1801-0008	REV.: A

ONCE PER BOARD

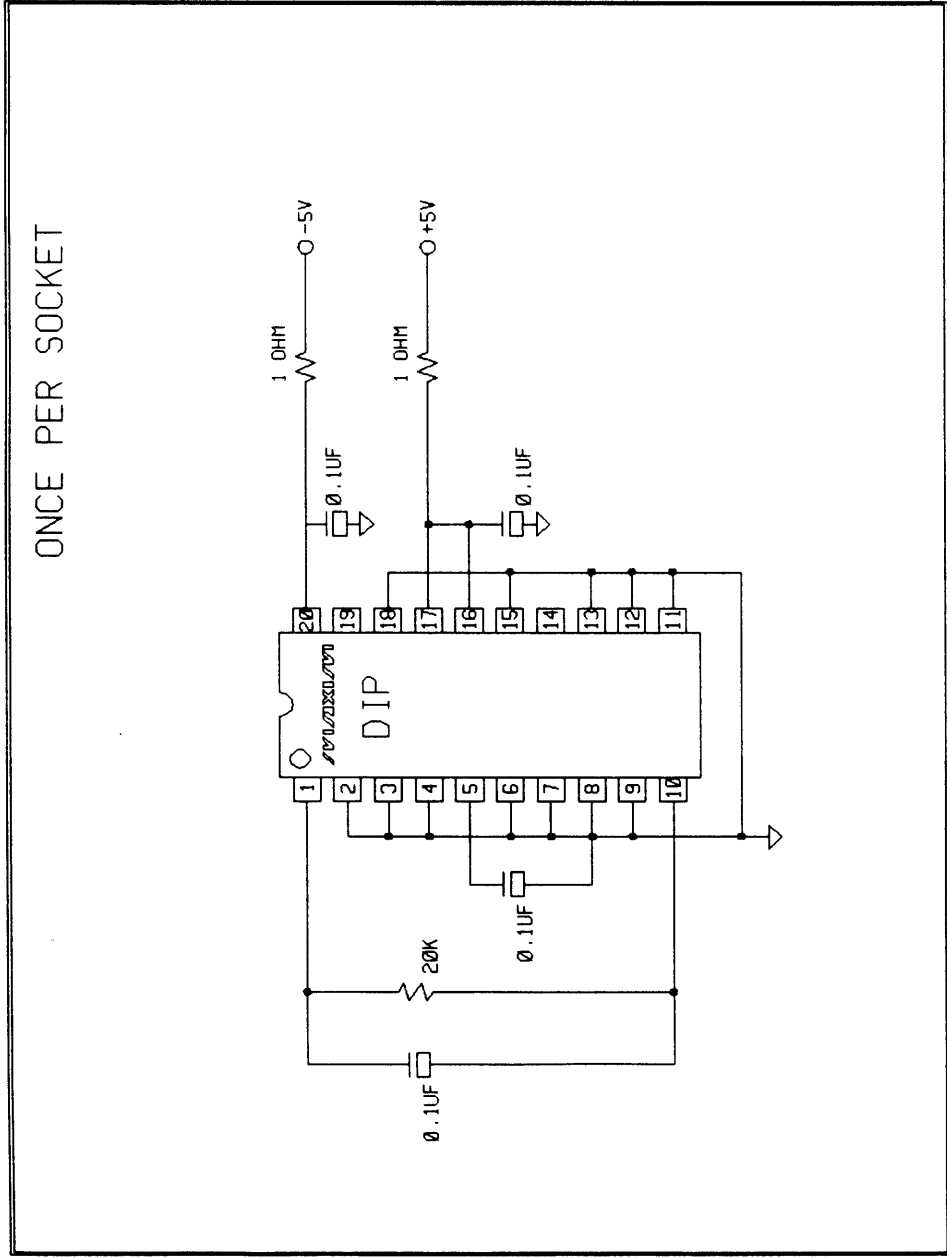

ONCE PER SOCKET

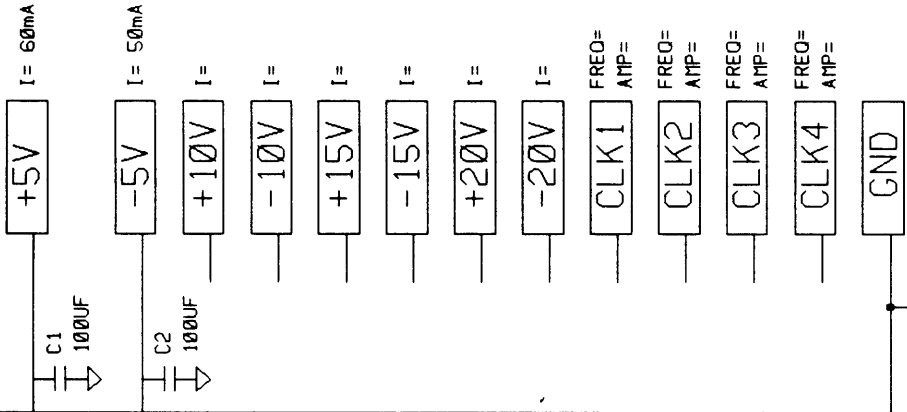

- STEADY STATE LIFE TEST IS PER MIL-STD-883 METHOD 1005.  
 - BURN-IN IS PER MIL-STD-883 METHOD 1015. COND. B

NOTES:

1. TEMPERATURE : 125C OR EQUIVALENT
2. TIME : 160 HOURS MIN. OR EQUIVALENT
3. ALL COMPONENTS AND MATERIAL MUST STAND 150C CONTINUOUS
4. APPROVED FOR [X] COMMERCIAL [X] HR/883

SPEC. NO. 06-5000 REV. A

DATE: 7/16/93

DRAWN BY:

BURN-IN SCHEMATIC

DEVICE TYPE:

MAX038