

TITLE

PLC G3 Physical Layer Specification

TYPE

SPECIFICATION

PROJECT

PLC G3 OFDM

ABSTRACT

This document specifies the Physical Layer block for an Orthogonal Frequency Division Multiplexing (OFDM) Powerline Communications (PLC) system as part of ERDF's G3 "Automated Meter Management" (AMM) technical specification.

CONTENT

1.	SCOPE.....	4
2.	ACRONYMS.....	5
3.	INTRODUCTION	7
4.	GENERAL DESCRIPTION.....	8
5.	PHYSICAL LAYER SPECIFICATION	9
5.1.	OVERVIEW OF THE SYSTEM	9
5.2.	SYSTEM FUNDAMENTAL PARAMETERS	10
5.3.	FRAME STRUCTURE	14
5.4.	PREAMBLE	15
5.5.	FRAME CONTROL HEADER.....	16
5.5.1.	CRC5.....	17
5.6.	SCRAMBLER.....	17
5.7.	FEC CODING	17
5.7.1.	REED SOLOMON ENCODER.....	18
5.7.2.	CONVOLUTIONAL ENCODER.....	18
5.7.3.	REPETITION CODING BY 4	19
5.7.4.	REPETITION CODING BY 6	19
5.8.	INTERLEAVER	19
5.9.	DBPSK/DQPSK MAPPING.....	22
5.9.1.	MAPPING FOR COHERENT BPSK	23
5.9.2.	MAPPING FOR DBPSK, DQPSK, ROBUST	23
5.10.	FREQUENCY DOMAIN PREAMPHASIS.....	24
5.11.	OFDM GENERATION (IFFT AND CP ADDITION).....	25
5.12.	WINDOWING	26
5.13.	ADAPTIVE TONE MAPPING & TRANSMIT POWER CONTROL	27
5.13.1.	PN MODULATING UN-USED SUBCARRIERS	29
5.14.	CROSSING MV/LV TRANSFORMER.....	30
5.15.	MV COUPLER	30
5.15.1.	COUPLER TECHNICAL CHARACTERISTICS	31
5.16.	AC PHASE DETECTION	32
6.	TRANSMITTER ELECTRICAL SPECIFICATIONS	34
6.1.	OUTPUT LEVEL MEASUREMENT	34
6.2.	TRANSMIT SPECTRUM MASK	34
6.3.	SPURIOUS TRANSMISSION	36
6.4.	SYSTEM CLOCK FREQUENCY TOLERANCE.....	36
6.5.	TRANSMIT CONSTELLATION ACCURACY	36
6.5.1.	TRANSMIT CONSTELLATION ERROR	36
6.5.2.	TRANSMIT MODULATION ACCURACY TEST	37
6.6.	TRANSMITTER SPECTRAL FLATNESS.....	37
7.	PHY PRIMITIVES.....	39
7.1.	DATA PRIMITIVE	39
7.1.1.	PD-DATA.REQUEST	39
7.1.2.	PD-DATA.CONFIRM	40
7.1.3.	PD-DATA.INDICATION	40
7.1.4.	PD-ACK.REQUEST	41
7.1.5.	PD-ACK.CONFIRM	41
7.1.6.	PD-ACK.INDICATION.....	42
7.2.	MANAGEMENT PRIMITIVE.....	42
7.2.1.	PLME_SET.REQUEST.....	42
7.2.2.	PLME_SET.CONFIRM	43
7.2.3.	PLME_GET.REQUEST	44

7.2.4. PLME_GET.CONFIRM..... 44
7.2.5. PLME_SET_TRX_STATE.REQUEST..... 44
7.2.6. PLME_SET_TRX_STATE.CONFIRM 45
7.2.7. PLME_CS.REQUEST 45
7.2.8. PLME_CS.CONFIRM..... 45

1. SCOPE

This document specifies the Physical Layer Entity for an Orthogonal Frequency Division Multiplexing (OFDM) Powerline Communications (PLC) system as part of ERDF's G3 "Automated Meter Management" (AMM) technical specification.

2. ACRONYMS

ACK: ACKnowledge
AFE: Analog Front End
AGC: Automatic Gain Control
AMM: Automated Meter Management
BPSK: Binary Phase Shift Keying
CC: Convolutional Code
CP: Cyclic Prefix
CRC: Cyclic Redundancy Check
DBPSK: Differential Binary Phase Shift Keying
DQPSK: Differential Quadrature Phase Shift Keying
FCH: Frame Control Header
FEC: Forward Error Correction
FFT: Fast Fourier Transform
FL: Frame Length
GF: Galois Field
GI: Guard Interval
ICI: Inter Carrier Interference
IEEE: Institute of Electrical and Electronics Engineers
IFFT: Inverse Fast Fourier Transform
IS: Information System
LSB: Least Significant Bit
LSF: Last Segment Flag
MAC: Media Access Control
MIB: Management Information Base
MPDU: MAC Protocol Data Unit
MSB: Most Significant Bit
NACK: Negative ACKnowledge
OFDM: Orthogonal Frequency Division Multiplexing
PAR: Peak to Average Ratio
PDC: Phase Detection Counter
PHY: PHYsical layer
PLC: Power Line Communication
PPDU: PHY Protocol Data Unit
PPM: Parts Per Million
PSD: Power Spectrum Density
PSDU: PHY Service Data Unit
RC: Repetition Code
RES: Reserved (bit fields)
RMS: Root Mean Square
RS: Reed-Solomon
RX: Receiver
S-FSK: Spread Frequency Shift Keying
S-Robust: Super Robust
SC: Segment Count

SN: Sequence Number

SNR: Signal to Noise Ratio

SYNCP, SYNCM: SYNChronization symbols

TMI: Tone Map Index

TX: Transmit

3. INTRODUCTION

Power line Communication has been used for many decades, but a variety of new services and applications require more reliability and higher data rates. However, the power line channel is very hostile. Channel characteristics and parameters vary with frequency, location, time and the type of equipment connected to it. The lower frequency regions from 10kHz to 200kHz are especially susceptible to interference. Besides background noise, it is subject to impulsive noise, and narrowband interference and group delays up to several hundred microseconds.

OFDM is a modulation technique that efficiently utilizes the allowed bandwidth within the Cenelec band, thereby allowing the use of advanced channel coding techniques. This combination enables a very robust communication in the presence of narrowband interference, impulsive noise, and frequency selective attenuation. OFDM-based PLC G3 specifications address the following main objectives:

1. Provide robust communication in extremely harsh power line channels
2. Provide a minimum of 20kbps effective data rate in the normal mode of operation
3. Ability to notch selected frequencies, allowing the cohabitation with S-FSK narrow band communication.
4. Dynamic tone adoption capability to select frequencies on the channel that do not have major interference, thereby ensuring a robust communication

As part of ERDF's G3 "Automated Meter Management" (AMM) technical specification described in the next section, this document describes the Physical Layer specification for an Orthogonal Frequency Division Multiplexing (OFDM) system in the CENELEC band addressing the above objectives.

4. GENERAL DESCRIPTION

ERDF is planning to develop and implement an Automatic Metering Management (AMM) system to manage the complete electricity supply chain, from electricity suppliers all the way to consumers. The system will provide a reliable two-way communication using OFDM-PLC between meters installed at the customers' premises and the concentrator, communicating in a Master and Slave configuration.

The following diagram illustrates AMM system.

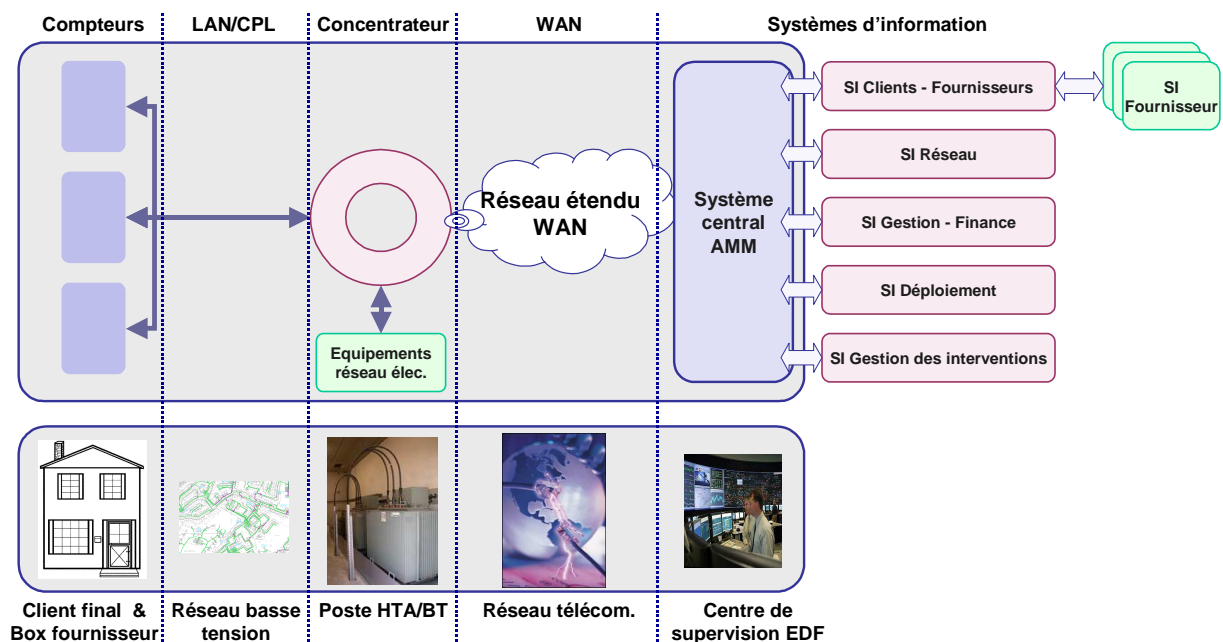

Figure 1- Network Architecture

The AMM architecture consists of the 5 following main components:

- The meter, which needs to integrate the capabilities of measuring power consumption, simple load control, and customer remote information.
- The hub, which acts as an intermediary between the AMM information system and the meters. Complementary equipment supplied by the electrical network that can be connected downstream of the hub,
- The PLC (LAN) technology, allowing the use of a low voltage electrical network to exchange data and commands between meters and hubs,
- Remote connection (WAN) allowing connection between the hubs and the AMM central IS,
- The central system, which not only handles its own functional services but also supplies metering services to the existing or forthcoming ENTERPRISE services (deployment IS, network IS, management-finance IS, customer-supplier IS-Intervention management IS, etc.). The customer-supplier IS is the interface between the Suppliers and AMM for handling their requirements.

5. PHYSICAL LAYER SPECIFICATION

This section specifies the physical layer block using Orthogonal Frequency Division Multiplexing (OFDM) system in the CENELEC band.

5.1. OVERVIEW OF THE SYSTEM

The power line channel is very hostile. Channel characteristics and parameters vary with frequency, location, time and the type of equipment connected to it. The lower frequency regions from 10kHz to 200kHz are especially susceptible to interference. Furthermore, the power line is a very frequency selective channel. Besides background noise, it is subject to impulsive noise often occurring at 50/60Hz, and narrowband interference and group delays up to several hundred microseconds.

OFDM is a modulation technique that can efficiently utilize the limited bandwidth of CENELEC, and thereby allows the use of advanced channel coding techniques. This combination facilitates a very robust communication over power line channel.

Figure 2 shows the block diagram of an OFDM system. The CENELEC bandwidth is divided into a number of sub-channels, which can be viewed as many independent PSK modulated carriers with different non-interfering (orthogonal) carrier frequencies. Convolutional and Reed-Solomon coding provide redundancy bits allowing the receiver to recover lost bits caused by background and impulsive noise. A time-frequency interleaving scheme is used to decrease the correlation of received noise at the input of the decoder, providing diversity.

The OFDM signal is generated by performing IFFT on the complex-valued signal points that are produced by differentially encoded phase modulation and which are allocated to individual sub-carriers. An OFDM symbol is built by appending a cyclic prefix to the beginning of each block generated by IFFT. The length of cyclic prefix is chosen so that a channel group delay will not cause successive OFDM Symbols or adjacent sub-carriers to interfere.

A blind channel estimator technique is used for link adaptation. Based on the quality of the receive signal, the receiver decides on the modulation scheme to be used. Moreover, the system differentiates the subcarriers with bad SNR and does not transmit data on them.

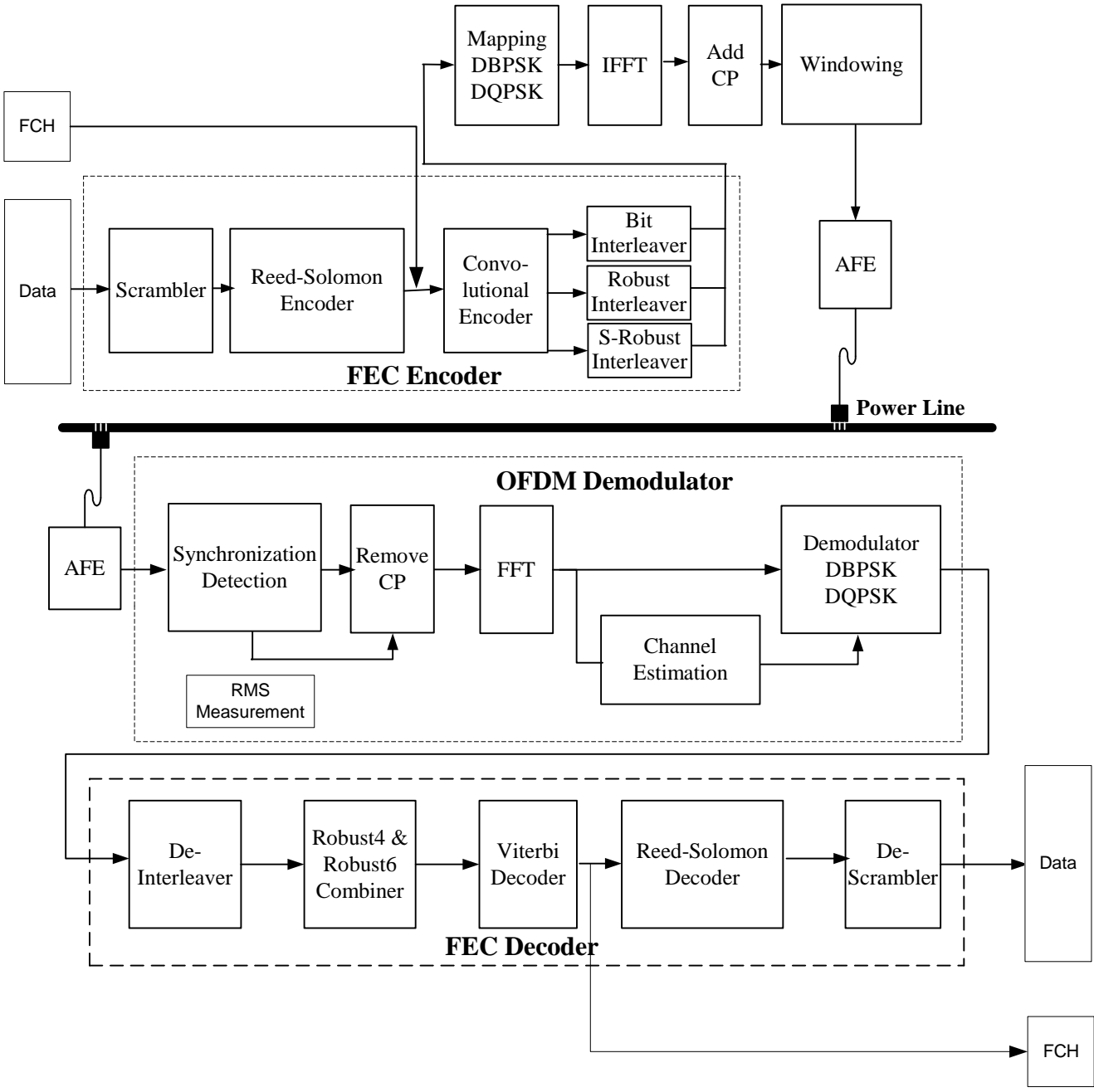

Figure 2- Block Diagram of OFDM Transceiver

5.2. SYSTEM FUNDAMENTAL PARAMETERS

The PLC G3 supports the portion between 35.9kHz to 90.6kHz of the CELENEC-A band. An OFDM with DBPSK and DQPSK modulation schemes per carrier is selected to support up to 33.4kbps data rate in Normal mode of operation. The DBPSK and DQPSK modulation for each carrier makes the receiver design significantly simpler since no tracking circuitry is required at the receiver for coherently detecting the phase of each carrier. Instead, the phases of carriers in the adjacent symbol are taken as reference for detecting the phases of the carriers in the current symbol.

There is potential to use this standard to support communication in frequencies up to 180kHz. As a result, the sampling frequency at the transmitter and receiver is selected to be 0.4MHz in order to provide some margin above the Nyquist frequency for signal filtering in the transmitter (for PSD shaping to remove the signal images) and at the receiver (for band selection and signal enhancement).

The maximum number of carriers that can be used is selected to be 128, resulting in an IFFT size of 256. This results in a frequency spacing between the OFDM carriers equal to $1.5625\text{kHz} * (F_s / N)$, where F_s is the sampling frequency and N is the IFFT size. Note that an imperfection such as sampling clock frequency variation can cause Inter Carrier Interference (ICI). In practice, the ICI caused by a typical sampling frequency variation of about 2% of the frequency spacing, is negligible. In other words, considering $\pm 20\text{ppm}$ sampling frequency in transmitter and receiver clocks, the drift of the carriers is approximately equal to 8Hz, which is approximately 0.5% of the selected frequency spacing. Considering these selections, the number of usable carriers is obtained as given in Table 1.

Table 1- Number of carriers for various bands.

	Number of Carriers	First Carrier (kHz)	Last Carrier (kHz)
CELENEC A	36	35.938	90.625

The system works in two different modes, namely Normal and Robust modes. In Normal mode, the FEC is composed of a Reed Solomon encoder and a convolutional encoder. The system also supports Reed Solomon code with parity of 8 and 16 Bytes.

In Robust mode the FEC is composed of Reed Solomon and convolutional encoders followed by a Repetition Code (RC). The RC code repeats each bit four times, making the system more robust to channel impairments. This of course will reduce the throughput by about factor of 4.

The number of symbols in each PHY (Physical Layer) frame is selected based on two parameters, the required data rate and the acceptable robustness. The number of symbols, Reed Solomon block sizes, and data rate associated with 36 tones is tabulated in Table 2 and Table 3.

Table 4 shows the data rate including the data transmitted in the FCH. To calculate the data rate, it is assumed that the packets are continuously transmitted with no inter frame time gap.

Table 2- RS block size for various Modulations

CENELEC A Number of Symbols	Reed Solomon Blocks DQPSK	Reed Solomon Blocks DBPSK	Reed Solomon Blocks Robust

	(Out/In) Bytes P16*	(Out/In) Bytes P16*	(Out/In) Bytes P8*
12	(53/37)	(26/10)	N/A
20	(89/73)	(44/28)	N/A
32	(143/127)	(71/55)	N/A
40	(179/163)	(89/73)	(21/13)
52	(233/217)	(116/100)	(28/20)
56	(251/235)	(125/109)	(30/22)
112	N/A	(251/235)	(62/54)
252	N/A	N/A	(141/133)

Table 3- Data rate for various Modulations (excluding FCH)

CENELEC A Number of Symbols	Data Rate (DQPSK) bps P16*	Data Rate (DBPSK) bps P16*	Data Rate (Robust) bps P8**
12	12103	3271	N/A
20	19456	7462	N/A
32	26489	11471	N/A
40	29693	13298	2423
52	33221	15309	3121
56	34160	15844	3257
112	N/A	20009	4647
252	N/A	N/A	5592

Table 4- Data rate for various Modulations (including FCH)

CENELEC A Number of Symbols	Data Rate (DQPSK) bps P16*	Data Rate (DBPSK) bps P16*	Data Rate (Robust) bps P8**
12	13453	4620	N/A

20	20556	8562	N/A
32	27349	12332	N/A
40	30445	14049	3192
52	33853	15941	3765
56	34759	16444	3867
112	N/A	20360	5002
252	N/A	N/A	5765

*: P16 is Reed Solomon with 16 bytes parity

** : P8 is Reed Solomon with 8 bytes parity

The data rate is calculated based on the number of symbols per PHY frame (N_S), the number of carrier per symbol (N_{carr}), and the number of parity bits added by FEC blocks. As an example, consider the system in the CENELEC A band working in Robust mode. The total number of bits carried by the whole PHY frame is equal to:

$$\text{Total_No_Bits} = N_S \times N_{carr} = 40 \times 36 = 1440\text{bits}$$

The number of bits required at the input of Robust encoder is given by:

$$\text{No_Bits_Robust} = 1440 \times \text{Robust}_{\text{Rate}} = 1440 \times \frac{1}{4} = 360\text{bits}$$

Considering the fact that the convolutional encoder has a rate equal to $\frac{1}{2}$ ($CC_{\text{Rate}} = \frac{1}{2}$), and also consider adding $CC_{\text{ZeroTail}} = 6\text{bits}$ of zeros to terminate the states of the encoder to all zero states, then the maximum number of symbols at the output of Reed Solomon encoder ($MAXRS_{\text{bytes}}$) must be equal to:

$$MAXRS_{\text{bytes}} = \text{floor}((\text{No_Bits_Robust} \times CC_{\text{Rate}} - CC_{\text{ZeroTail}})/8) = \text{floor}((360 \times \frac{1}{2} - 6)/8) = 21$$

Removing 8 symbols associated with the parity bits (in Robust mode) we obtain:

$$\text{DataLength} = (21 - \text{ParityLength}) \times 8 = 104 \text{ bits}$$

These 104 bits are carried within the duration of a PHY frame. The duration of a PHY frame is calculated by the following formula:

$$T_{\text{Frame}} = (((N_S + N_{\text{FCH}}) \times (N_{\text{CP}} + N - N_O) + (N_{\text{pre}} \times N)))/F_s$$

Where N_{pre} , N , N_O and N_{CP} are the number of symbols in the preamble, FFT length, the number of samples overlapped at each side of one symbol and the number of samples in the cyclic prefix, respectively. N_{FCH} is the number of symbols in the FCH. The F_s is the sampling frequency. Typical values for all these parameters for various frequency bands are given in Table 5.

Table 5- System Specifications

Number of FFT points	$N = 256$
Number of overlapped samples	$N_O = 8$
Number of cyclic Prefix samples	$N_{CP} = 30$
Number of FCH symbols	$N_{FCH} = 13$
Sampling frequency	$F_s = 0.4 \text{ MHz}$
Number of symbols in Preamble	$N_{pre} = 9.5$

Substituting the above numbers in the equation, The T_{Frame} (PHY frame duration) for a 40-symbol frame is obtained as follows:

$$T_{Frame} = ((40+13) \times (256 + 22) + (9.5 \times 256)) / 400000 = 0.043 \text{ sec.}$$

Therefore the data rate is calculated by:

$$\text{Data rate} = 104 / 0.042 \sim 2.4 \text{ kbps}$$

5.3. FRAME STRUCTURE

The PHY supports two types of frames. A typical data frame for the OFDM PHY is shown in Figure 3. Each frame starts with a preamble, which is used for synchronization and detection in addition to AGC adaptation. SYNCP simply refers to symbols that are multiplied by +1 in the sign function above, and SYNCM refers to symbols multiplied by -1. The Preamble consists of eight SYNCP symbols followed by one and a half SYNCM symbols with no cyclic prefix between adjacent symbols. The first symbol includes raised cosine shaping on the leading points. The last half symbol also includes raised cosine shaping on the trailing points. The preamble is followed by 13 data symbols allocated to Frame Control Header (FCH). FCH has the important control information required to demodulate the data frame. Data symbols are transmitted next. In the figures, ‘GI’ stands for guard interval, which is the interval containing the cyclic prefix.

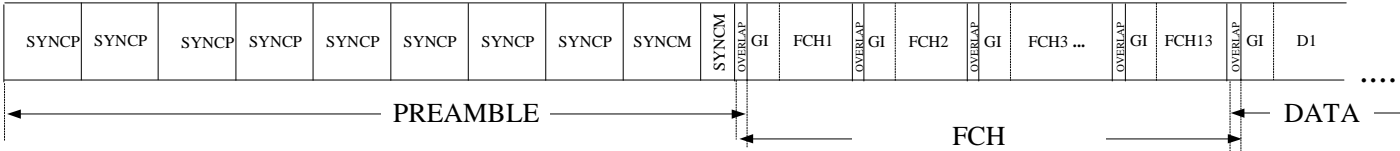

Figure 3- Typical Data Frame Structure

The PHY also supports an ACK/NACK frame, which only consists of preamble and the FCH. The frame structure of the ACK frame is shown in Figure 4. The bit fields in the FCH, explained in section 5.5 will perform the ACK/NACK signaling.

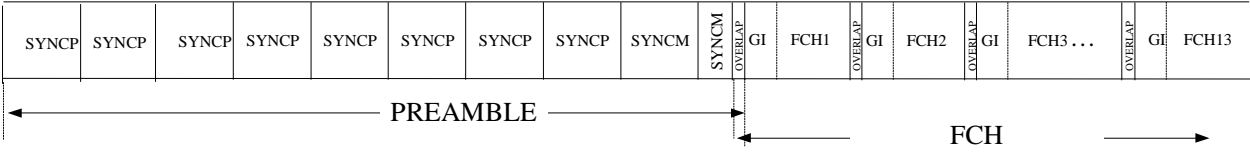

Figure 4- ACK/NACK Frame Structure

5.4. PREAMBLE

The preamble is composed of 8 identical P symbols and 1½ identical M symbols. Each of the P and M symbols is 256 samples and is pre-stored in the transmitter and transmitted right before the data symbols. The P symbols are used for AGC adaptation, symbol synchronization, channel estimation and initial phase reference estimation. The M symbols are identical to P symbols except that all the carriers are π phase shifted. At the receiver, the phase distance between symbol P and symbol M waveforms is used for frame synchronization. A P symbol is generated by creating 36 equally spaced carriers with the phase of each carrier given by ϕ_c as shown in Table 6. One way to generate this signal is to start in the frequency domain and create 36 complex carriers with the initial phases ϕ_c , as shown in Table 6. Figure 9 shows how the 36 subcarriers are mapped to the IFFT input where the first modulated subcarrier is subcarrier 23 and the last modulated subcarrier is subcarrier 58.

Table 6- Phase Vector Definition

c	ϕ_c	c	ϕ_c	c	ϕ_c
0	$2(\pi/8)$	12	$1(\pi/8)$	24	$13(\pi/8)$
1	$1(\pi/8)$	13	$11(\pi/8)$	25	$2(\pi/8)$
2	$0(\pi/8)$	14	$5(\pi/8)$	26	$6(\pi/8)$
3	$15(\pi/8)$	15	$14(\pi/8)$	27	$10(\pi/8)$
4	$14(\pi/8)$	16	$7(\pi/8)$	28	$13(\pi/8)$
5	$12(\pi/8)$	17	$15(\pi/8)$	29	0
6	$10(\pi/8)$	18	$7(\pi/8)$	30	$2(\pi/8)$
7	$7(\pi/8)$	19	$15(\pi/8)$	31	$3(\pi/8)$
8	$3(\pi/8)$	20	$6(\pi/8)$	32	$5(\pi/8)$
9	$15(\pi/8)$	21	$13(\pi/8)$	33	$6(\pi/8)$
10	$11(\pi/8)$	22	$2(\pi/8)$	34	$7(\pi/8)$
11	$6(\pi/8)$	23	$8(\pi/8)$	35	$7(\pi/8)$

5.5. FRAME CONTROL HEADER

The four data symbols immediately after the preamble are reserved for the frame control header (FCH). The FCH is a data structure transmitted at the beginning of each data frame and contains information regarding the current frame. It has information about the type of frame, tone map index of the frame, length of the frame, etc. The FCH data is protected with CRC5. Table 7 defines the structure of FCH. The FCH shall use the default tone MAP (all allowed subcarriers).

Table 7- FCH bit fields

Field	Byte	Bit number	Bits	Definition
PDC	0	7-0	8	Phase detection counter
MOD	1	7-6	2	Modulation type: 0 – ROBO; 1 –DBPSK 2 - DQPSK
FL	1	5-0	6	PHY frame length in PHY symbols
TM[0:7]	2	7-0	8	TM[0:7] – Tone map
TM[8]	3	7	1	TM[8] – Tone map
DT	3	6-4	3	Delimiter type: 000: Start of frame with no response expected; 001: Start of frame with response expected; 010: Positive acknowledgement (ACK) 011: Negative acknowledgement (NACK) 100-111: Reserved
FCCS	3	3-0	4	Frame Control Check Sequence (CRC5)
	4	7	1	
ConvZeros	4	6-1	6	6 zeros for convolutional encoder

- The frame length bit field gives the number of symbols in the frame based on the formula:
Number of Symbols = FL*4

5.5.1. CRC5

An 5-bit cyclic redundancy check (CRC) is used to for error detection in FCH. The CRC5 is computed as a function of the 34-bit sequence. The CRC5 is calculated using the following standard generator polynomial of degree 5:

$$G(x) = x^5 + x^2 + 1$$

The CRC5 is the remainder of the division of the FCH polynomial by the generator polynomial. It should be noted that as the CRC5 is not as robust as CRC8, guardbands can be used to make it more robust (such as using reserved values and checking the validity of combination of received values).

5.6. SCRAMBLER

The data scrambler block helps give the data a random distribution. The data stream is ‘XOR-ed’ with a repeating PN sequence using the following generator polynomial:

$$S(x) = x^7 \oplus x^4 \oplus 1$$

This is illustrated in Figure 5. The bits in the scrambler are initialized to all ones at the start of processing each PHY frame.

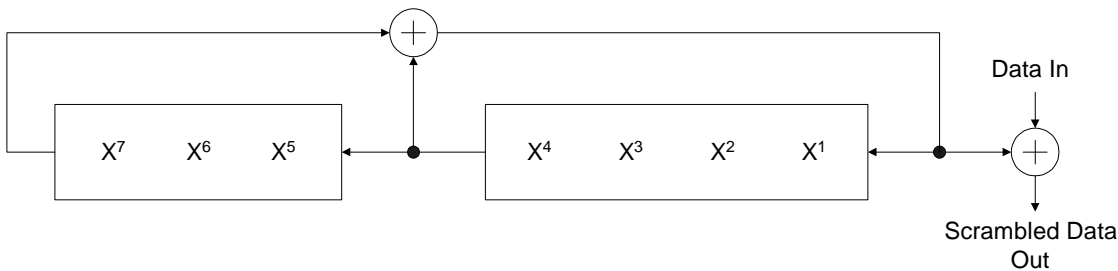

Figure 5- Data Scrambler

5.7. FEC CODING

The FEC encoder is composed of a Reed-Solomon encoder followed by a convolutional encoder. In Robust mode, an extra encoder, namely, Repetition Code (RC), is used after the convolutional encoder in order to repeat the bits at the output of convolutional encoder four times.

5.7.1. REED SOLOMON ENCODER

Data from the scrambler is encoded by shortened systematic RS (N = 255, K = 239, T = 8) and RS (N = 255, K = 247, T = 4) codes using Galois Field GF(2⁸). The RS symbol word length (i.e., the size of the data words used in the Reed-Solomon block) is fixed at 8 bits. The value of T (number of correctable symbol errors) can be either 4 or 8 for different configurations. For Robust mode, the code with T=4 is used. The number of parity words in a RS-block is 2T bytes.

Code Generator Polynomial $g(x) = \prod_{i=1}^{2T} (x - \alpha^i)$

Field Generator Polynomial: $p(x) = x^8 + x^4 + x^3 + x^2 + 1$ (435 octal)

The representation of α^0 is “00000001”, where the left most bit of this RS symbol is the MSB and is first in time from the scrambler and is the first in time out of the RS encoder.

The arithmetic is performed in the Galois Field GF(2⁸), where α is a primitive element that satisfies the primitive binary polynomial $x^8 + x^4 + x^3 + x^2 + 1$. A data byte ($d^7, d^6, \dots, d^1, d^0$) is identified with the Galois Field element $d^7\alpha^7 + d^6\alpha^6 + \dots + d^1\alpha + d^0$.

The first bit in time from the Data Scrambler becomes the most significant bit of the symbol at the input of the RS encoder. Each RS encoder input block is formed by one or more fill symbols (“00000000”) followed by the message symbols. Output of the RS encoder (with fill symbols discarded) proceeds in time from first message symbol to last message symbol followed by parity symbols, with each symbol shifted out most significant bit first.

5.7.2. CONVOLUTIONAL ENCODER

The bit stream at the output of the Reed-Solomon block is encoded with a standard rate = 1/2, K=7 Convolutional encoder. The tap connections are defined as $x = 0b1111001$ and $y = 0b1011011$, as shown in Figure 6.

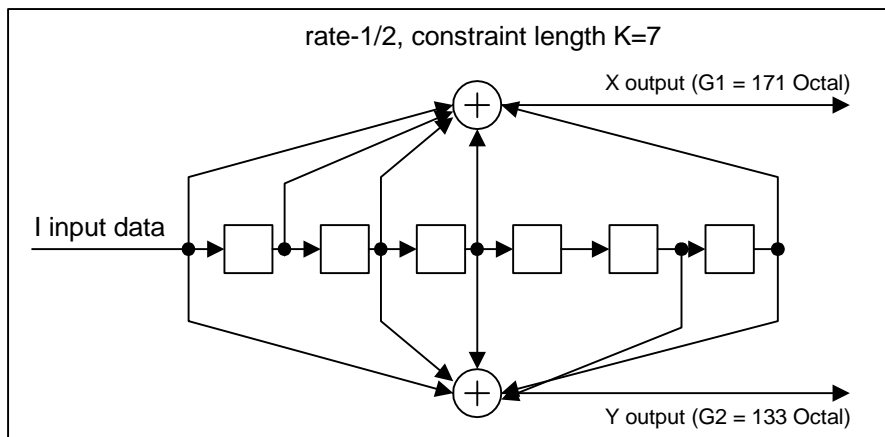

Figure 6- Convolutional encoder

When the last bit of data to the convolutional encoder has been received, the convolutional encoder inserts six tail bits, which are required to return the convolutional encoder to the "zero state". This

improves the error probability of the convolutional decoder, which relies on future bits when decoding. The tail bits are defined as six zeros.

5.7.3. REPETITION CODING BY 4

In Robust mode, the resulting packet is repeated four times by the interleaver as described in section 5.8. This encoder is only activated in Robust mode. The repetition is done by repeating the frame four times. For the FCH, the super robust mode is used. This mode uses repetition of 6 for increased robustness.

5.7.4. REPETITION CODING BY 6

In Super Robust mode, the resulting packet is repeated six times by the interleaver as described in section 5.8. The repetition is done by repeating the frame six times. The super Robust mode is used only for frame control portion (FCH) of a data frame.

5.8. INTERLEAVER

The interleaver is designed such that it can provide protection against two different sources of errors:

- A burst error that corrupts a few consecutive OFDM symbols
- A frequency deep fade that corrupts a few adjacent frequencies for a large number of OFDM symbols

To fight both problems at the same time, interleaving is done in two steps. In the first step, each column is circularly shifted a different number of times. Therefore, a corrupted OFDM symbol is spread over different symbols. In the second step, each row is circularly shifted a different number of times, which prevents a deep frequency fade from disrupting the whole column. The amount of circular shifts is determined by the parameters m_i , m_j , n_i , and n_j which are selected based on the number of subcarriers in each OFDM symbol (m) as well as the number of OFDM symbols in each interleaving block (n). The figure below shows the order of bits as they are put in the interleaver buffer (i.e. row by row).

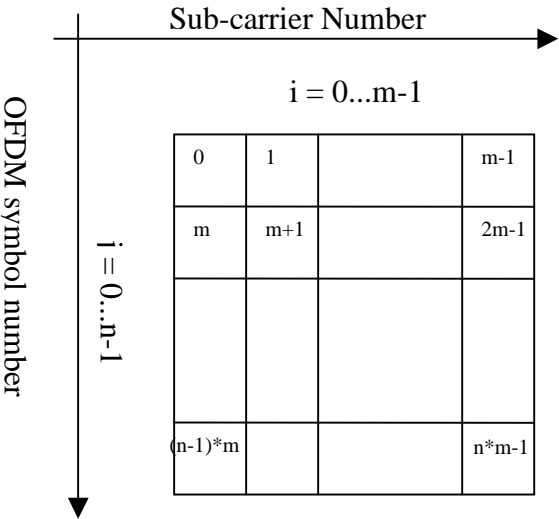

The relation between input and output indexes is determined from the following relations

Original bit position (i,j) where i=0,1,...,m-1 and j=0,1,...,n-1

Interleaved position (I,J) where

$$J = (j * n_j + i * n_i) \% n$$

$$I = (i * m_i + J * m_j) \% m$$

NOTE: Good interleaving patterns will be generated only if
 $GCD(m_i,m) = GCD(m_j,m) = GCD(n_i,n) = GCD(n_j,n) = 1.$

A simple search is done to find a good set of parameters based on m and n.
 The following figure displays the spreading behavior of the interleaver for

n = 8, m = 10, n_j = 5, n_i = 3, m_i = 3 and m_j = 7

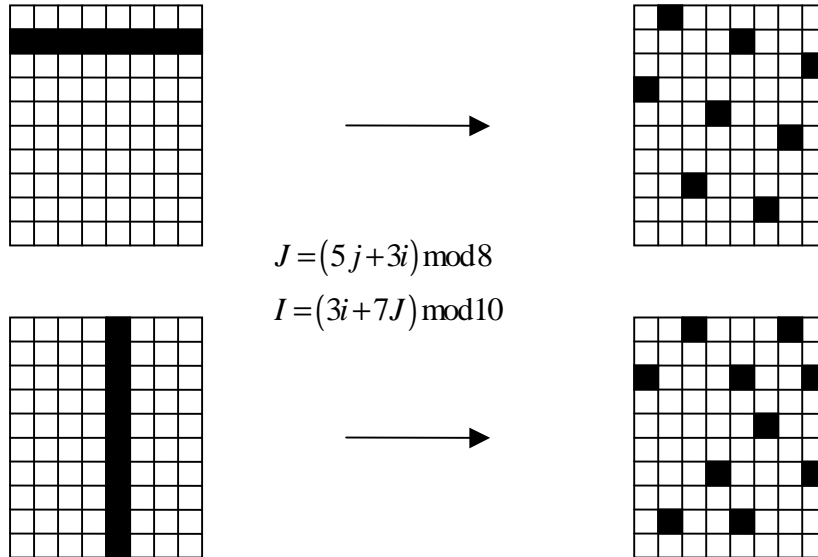

The following piece of code is used for generating a good interleaving pattern. It needs two parameters, freqNum which is the number of data-holding sub-carriers, and symbNum which is the number of OFDM symbols. The interleaving table will be generated in ILV_TBL array.

```
void Interleaver_init( int freqNum, int symbNum )
{
    volatile int i, j, I, J, m, n, m_i, m_j, n_i, n_j;

    n = symbNum;
    m = freqNum;

    n_j = 1; n_i = 1;
    m_i = 1; m_j = 1;

    for ( i = 3; i < n; i++ )
    if ( gcd(n,i) == 1 )
    {
        n_j = i;
        break;
    }
    for ( i++; i < n; i++ )
    if ( gcd(n,i) == 1 )
    {
        n_i = i;
        break;
    }
}
```

```

for ( i = 3; i < m; i++ )
if ( gcd(m,i) == 1 )
{
    m_i = i;
    break;
}
for ( i++; i < m; i++ )
if ( gcd(m,i) == 1 )
{
    m_j = i;
    break;
}

ILV_SIZE = m * n

for ( j = 0; j < n; j++ )
    for ( i = 0; i < m; i++ )
        {
            J = ( j * n_j + i * n_i ) % n;
            I = ( i * m_i + J * m_j ) % m;
            ILV_TBL[ i + j * m ] = I + J * m;
        }
}

```

Interleaving itself can be done using the following piece of code:

```

for ( i = 0; i < size; i += ILV_SIZE )
for ( j = 0; j < ILV_SIZE; j++ )
    y[ i + ILV_TBL[j] ] = (i+j) < size ? x[i+j] : 0;

```

Similarly, deinterleaving can be done using

```

for ( i = 0; i < size; i += ILV_SIZE )
for ( j = 0; j < DLV_SIZE; j++ )
    y[i+j] = x[ i + ILV_TBL[j] ];

```

5.9. DBPSK/DQPSK MAPPING

Each carrier is modulated with Coherent/Differential Binary or Differential Quadrature Phase Shift Keying (BPSK, DBPSK or DQPSK) or Robust. Robust modulation is a robust form of DBPSK that provides extensive time and frequency diversity to improve the ability of the system to operate under adverse conditions. Forward error correction coding (FEC) is applied to both the frame control information (Super Robust encoding) and the data (concatenated Reed-Solomon and Convolutional Encoding) in the communication packet.

The mapping block is also responsible for assuring that the transmitted signal conforms to the given Tone Map and Tone Mask. The Tone Map and Mask are concepts of the MAC layer. The Tone Mask is a predefined (static) system-wide parameter defining the start, stop and notch frequencies. The Tone Map is an adaptive parameter that, based on channel estimation, contains a list of carriers that are to be used for a particular communication between two modems. For example, carriers that suffer deep fades can be avoided, and no information is transmitted on those carriers.

5.9.1. MAPPING FOR COHERENT BPSK

Each frame control symbol uses a pre-defined phase reference (which is used as preamble). A binary sequence is encoded as a phase vector, where each entry is determined as a phase shift with respect to the phase reference vector ϕ . A phase shift of zero degrees indicates a binary “0”, and a phase shift of 180 degrees indicates a binary “1”. The mapping function for coherent BPSK must obey the Tone Mask, thus carriers that are masked are not assigned phase symbols. The data encoding for (coherent) BPSK is defined below in Table 8.

Table 8- BPSK Encoding Table of k-th Subcarrier

Input Bit	Output Phase
0	ϕ_k
1	$\phi_k + \pi$

5.9.2. MAPPING FOR DBPSK, DQPSK, ROBUST

Data bits are mapped for differential modulation (DBPSK, DQPSK or Robust). Instead of using the phase reference vector ϕ , each phase vector uses the same carrier, previous symbol, as its phase reference. The first data symbol uses the pre-defined phase reference vector. The data encoding for Robust, DBPSK and DQPSK is defined in Table 9 and Table 10, where Ψ_k is the phase of the k-th carrier from the previous symbol. In DBPSK (and Robust) a phase shift of 0 degrees represents a binary “0” and a phase shift of 180 degrees represent a binary “1”. In DQPSK a pair of 2 bits is mapped to 4 different output phases. The phase shifts of 0, 90, 180, and 270 degrees represent binary “00”, “01”, “11”, and “10”, respectively.

Table 9- DBPSK and Robust Encoding Table of k-th Subcarrier

Input Bit	Output Phase
0	Ψ_k
1	$\Psi_k + \pi$

Table 10- DQPSK Encoding Table of k-th Subcarrier

Input Bit Pattern (X,Y), Y is from first interleaver matrix	Output Phase
00	Ψ_k
01	$\Psi_k + \pi/2$
11	$\Psi_k + \pi$
10	$\Psi_k + 3\pi/2$

Alternatively, the phase differences used to compute “output phases” in Table 9 and Table 10 can be represented in a constellation diagram (with reference phase assumed equal to 0 degrees), as shown in Figure 7.

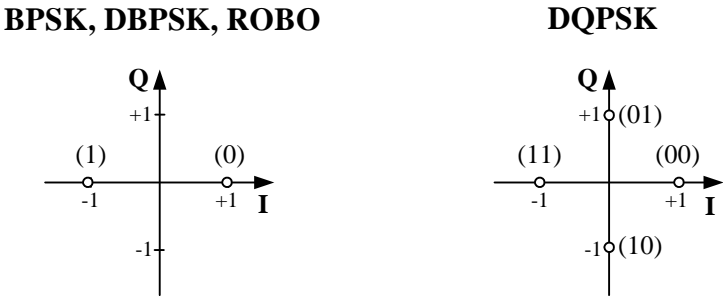

Figure 7- Constellation Encoding

5.10. FREQUENCY DOMAIN PREEMPHASIS

The purpose of this block is to provide frequency shaping to the transmit signal in order to compensate for attenuation introduced to the signal as it goes through the power line.

The frequency-domain pre-emphasis filter shall consist of a multiplier that multiplies the complex frequency domain samples of an OFDM symbol with 128 real filter coefficients. If the optional TXCOEFF parameters are not implemented, the frequency domain preemphasis filter should use values to satisfy the spectrum flatness criterion stated in section 6.6. Otherwise, the filter coefficients are 4 bits representing signed values from -8 to +7. Their values are computed from the TXRES and TXCOEFF parameters that are part of the Tone Map Response message that the destination station sends to the source station as described in section 5.13. The filter multiplies the first 128 frequency-domain complex samples of an OFDM symbol with the 128 real coefficients of the filter. The rest of the 128 frequency-domain samples of the OFDM symbol shall be set to zero and shall not be multiplied by the filter coefficients. Figure 8 below shows a block diagram of the preemphasis filter. The output of the filter shall be the input to the IFFT.

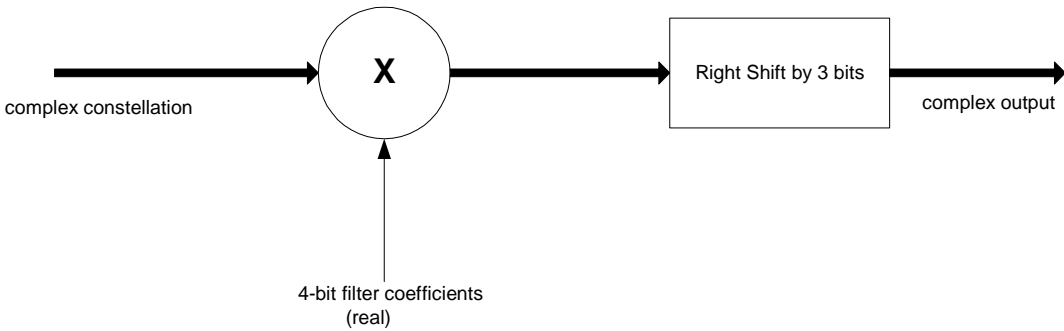

Figure 8- Block Diagram of the Preemphasis filter

5.11. OFDM GENERATION (IFFT AND CP ADDITION)

The OFDM signal can be generated using IFFT. The IFFT block takes the 256-point IFFT of the input vector and generates the main 256 time-domain OFDM words pre-pended by 30 samples of cyclic prefix. In other words, we take the last 30 samples at the end of the IFFT and place them in front of symbol. The useful output is the real part of the IFFT coefficients. The Input/Output configuration is as depicted in Figure 9.

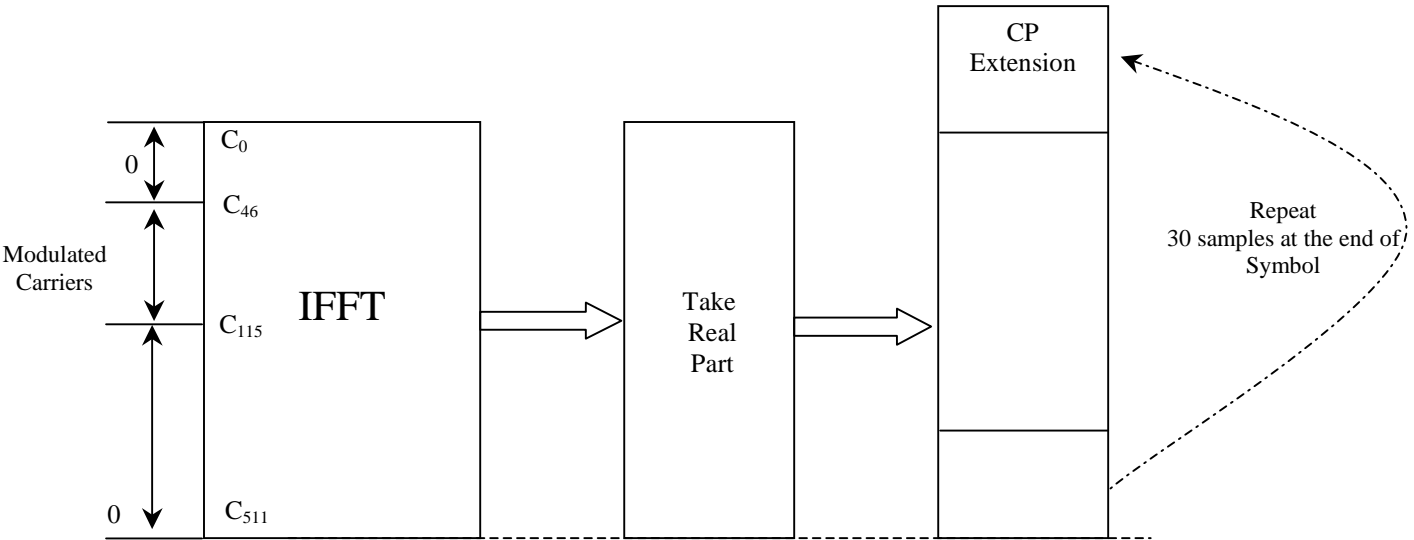

Figure 9- IFFT Input/Output and CP addition

5.12. WINDOWING

In order to reduce the out of band emission and to reduce the spectral side lobe, the Raised Cosine shaping is applied to all the data symbols. Then the tails and heads of successive symbols are overlapped and added together. This process is described below. Each side of a symbol is first shaped by a Raised Cosine function as shown in Figure 10.

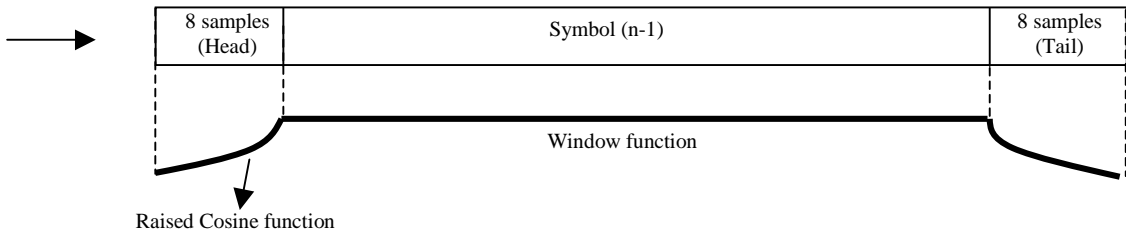

Figure 10- Raised Cosine windowing

The windowing function at each 8-sample boundary is a Raised Cosine function and its values are given in Table 11. The window function has a value equal to one at all the remaining samples of the symbol. The 8 tail and 8 head shaped samples of the symbol from each side of symbol are overlapped with the tail and head samples of adjacent symbols as shown in

Figure 11. In other words, in order to construct the n th symbol, firstly its 8 head samples are overlapped with the 8 tail samples of the $(n-1)^{th}$ symbol and its 8 tail samples is overlapped with the 8 head samples of the $(n+1)^{th}$ symbol. Finally, the corresponding overlapped parts are added together. Note that the head of the first symbol is overlapped with the tail of preamble. And the tail of last symbol is sent out with no overlapping applied.

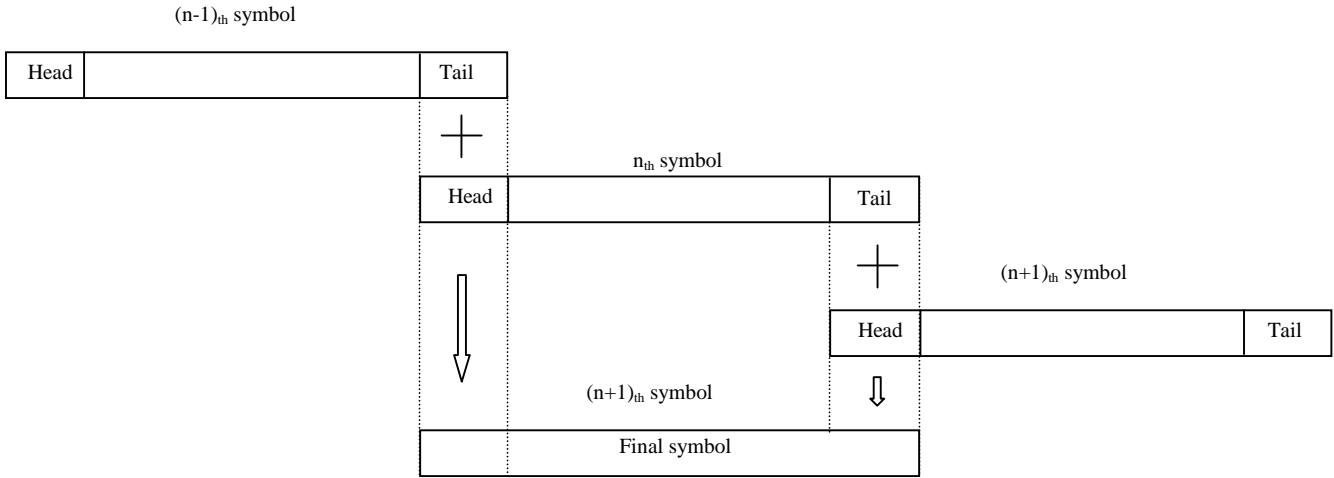

Figure 11- Overlap/add

Table 11- The Raised Cosine Samples

	Head samples	Tail samples
1	0	0.9619
2	0.0381	0.8536
3	0.1464	0.6913
4	0.3087	0.5000
5	0.5000	0.3087
6	0.6913	0.1464
7	0.8536	0.0381
8	0.9619	0

5.13. ADAPTIVE TONE MAPPING & TRANSMIT POWER CONTROL

G3 PLC shall estimate the SNR of the received signal sub carriers and adaptively select the usable tones and optimum modulation and code rate (including DBPSK, DQPSK and the Robust mode) to ensure reliable communication over the powerline channel. It shall also specify what power level the remote transmitter shall use and what gain values it should apply for various sections of the spectrum. The per-tone quality measurement enables the system to adaptively avoid transmitting data on sub carriers with poor quality. Using a tone map indexing system, where the index is passed from receiver to transmitter and vice versa, allows the receiver to adaptively select which sub carriers will be used for transmission and which ones will be used to send dummy data that the receiver will ignore.

The goal of the adaptive tone mapping is to allow the G3 PLC receiver to achieve the greatest possible throughput given the channel conditions existing between them. In order to accomplish this goal, the receiver shall inform the remote transmitter which tones it should use to send data bits on, and which tones it should use to send dummy data bits that the receiver shall ignore. The receiver shall also inform the remote transmitter how much amplification or attenuation it should apply to each of the tones.

The source station may request a destination station to estimate a channel condition by setting TMR bit of Frame Control Header as described in section 5.5.

The destination station has to estimate this particular communication link between two points and choose optimal PHY parameters. This information will be sent back to the originator as a *Tone Map Response*.

The detailed procedure is described in section 4.3.1 of MAC specification document.

Figure 12 below shows the format of the *Tone Map Response* message that is sent from the destination station back to the source station.

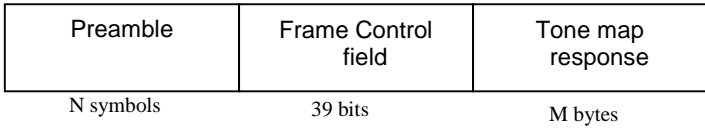

Figure 12- Frame structure of a Tone Map Response message

The *Tone Map Response* message parameters are shown in Table 12.

Table 12- Tone Map Response message description

Field	Byte	Bit number	Bits	Definition
TXRES	0	7	1	Tx Gain resolution corresponding to one gain step. 0 : 6 dB 1 : 3 dB
TXGAIN	0	6-3	4	Desired Transmitter gain specifying how many gain steps are requested.
MOD	0	2-1	2	Modulation type: 0 – ROBO; 1 –DBPSK 2 - DQPSK
TM[8]	0	0	1	Tone Map [8]
TM[0:7]	1	7-0	8	Tone Map [7:0]
LQI	2	7-0	8	Link Quality Indicator
TXCOEF[3:0]	3	7-4	4	Specifies number of gain steps requested for 10kHz-20kHz spectrum
TXCOEF[7:4]	3	3-0	4	Specifies number of gain steps requested for 20kHz-30kHz spectrum
TXCOEF[11:8]	4	7-4	4	Specifies number of gain steps requested for 30kHz-40kHz spectrum
TXCOEF[15:12]	4	3-0	4	Specifies number of gain steps requested for 40kHz-50kHz spectrum
TXCOEF[19:16]	5	7-4	4	Specifies number of gain steps requested for 50kHz-60kHz spectrum
TXCOEF[23:20]	5	3-0	4	Specifies number of gain steps requested for 60kHz-70kHz spectrum
TXCOEF[27:24]	6	7-4	4	Specifies number of gain steps requested for 70kHz-80kHz spectrum
TXCOEF[31:28]	6	3-0	4	Specifies number of gain steps requested for 80kHz-90kHz spectrum

1. MOD: Parameter that specifies the desired modulation type. The destination station computes the SNR of the *Tone Map Request* message that it receives from the source station and decides which of the three modulation modes (DBPSK, DQPSK, or Robust) it wants the source to use

when sending next data frame or *Tone Map Request* message. Table 13 lists the allowed bit values and the modulation modes they correspond to.

Table 13- Modulation Method Field

MOD Value	Interpretation
00	Robust Modulation
01	DBPSK Modulation
10	DQPSK Modulation
11	Reserved

- 2. TXRES: Parameter that specifies the transmit gain resolution corresponding to one gain step.
- 3. TXGAIN: Parameter that specifies to remote transmitter the total amount of gain that it should apply to its transmitted signal. The value in this parameter shall specify the total number of gain steps needed. The receiver computes the received signal level and compares it to a VTARGET (pre-defined desired receive level). The difference in dB between the two values is mapped to a 5-bit value that specifies the amount of gain increase or decrease that the remote transmitter shall apply to the next frame to be transmitted. A 0 in the most significant bit indicates a positive gain value, hence an increase in the transmitter gain, and a 1 indicates a negative gain value, hence a decrease in the transmitter gain. A value of TXGAIN = 0 informs the transmitter to use the same gain value it used for previous frame (Optional).
- 4. TM: Parameter that specifies the Tone Map. The receiver estimates the per-tone quality of the channel and maps each subband (6 tones per subband) to a one-bit value where a value of 0 indicates to the remote transmitter that dummy data should be transmitted on the corresponding sub carrier while a value of 1 indicates that valid data should be transmitted on the corresponding sub carrier.
- 5. TXCOEF: Parameter that specifies transmitter gain for each 10kHz section of the available spectrum. The receiver measures the frequency-dependent attenuation of the channel and may request the transmitter to compensate for this attenuation by increasing the transmit power on sections of the spectrum that are experiencing attenuation in order to equalize the received signal. Each 10kHz section is mapped to a 4-bit value where a 0 in the most significant bit indicates a positive gain value, hence an increase in the transmitter gain is requested for that section, and a 1 indicates a negative gain value, hence a decrease in the transmitter gain is requested for that section. Implementing this feature is optional and it is intended for frequency selective channels. If this feature is not implemented, the value zero should be used.

5.13.1. PN MODULATING UN-USED SUBCARRIERS

The mapping function for DBPSK, DQPSK, and Robust must obey the Tone Mask, thus carriers that are masked are not assigned phase symbols, and the amplitude is zero. When the modulation type is DBPSK or DQPSK the mapping function also obeys the Tone Map. When a carrier is encountered on which no information is to be transmitted, the mapping function substitutes a binary value from a Pseudo Noise (PN) sequence. The binary value shall be used as the value for both bits in the case of DQPSK.

The PN sequence shall be generated using the same generator polynomial introduced in section 5.6. The bits in the PN sequence generator shall all be initialized to ones at the start of processing each frame and sequenced to the next value after every mapped, unmapped or masked carrier. The

first value of the PN sequence (the output when all bits are initialized to ones) corresponds to carrier number 0 of the first OFDM symbol of each frame and the 70th value corresponds to carrier number 0 of the second OFDM symbol.

5.14. CROSSING MV/LV TRANSFORMER

The PLC G3 system shall have the ability to communicate in both low voltage power lines as well as high voltage power lines. When operating in a high-voltage power line it shall be able to communicate with low-voltage power lines. This means that the receiver on the LV side must be able to detect the transmitted signal after it has been severely attenuated as a result of going through a MV/LV transformer. As the signal goes through the transformer it is expected to experience overall severe attenuation in its power level as well as frequency-dependent attenuation that attenuates higher frequencies. Both transmitter and receiver shall have mechanisms to compensate for this attenuation. The transmitter shall have the capability to adjust its overall signal level as well as shape its power spectrum, while the receiver shall have both an analog and digital AGC (Automatic Gain Control) in order to achieve enough gain to compensate for the overall attenuation.

The PLC G3 system, in addition to being able to operate in normal mode, shall have the capability to operate as a repeater. When configured in "repeater" mode, the PLC G3 system shall decode received frames from the channel then re-transmits them at a higher signal level in order to partially compensate for the attenuation introduced by the transformer. The repeater, when needed, shall be placed on the LV side of the MV/LV transformer.

5.15. MV COUPLER

The PLC G3 modem will interface with the MV power line through a PLC coupling device, which is basically a high-pass filter whose purpose is to permit the PLC signal to pass, but reject the power system frequency and protect the communications equipment from the power system voltage and transient voltages caused by switching operations.

The basic circuit diagram is shown in Figure below. A complete coupling comprises a line trap to prevent the PLC signal from being short-circuited by the substation, and a coupling filter formed by the coupling capacitor and the coupling device.

For the PLC G3 modem, resolving impedance mismatching is very important in the sense of transferring maximum power to the signal input terminal of the MV power distribution lines. It is recommended that any transformer being used should be verified by measuring transmission and reflection characteristics through vector network analyzer.

The proposed coupling interface, shown in Figure 13, should interface between the PLC device and the MV medium (with 24 kV and impedance of 75 Ω to 175 Ω).

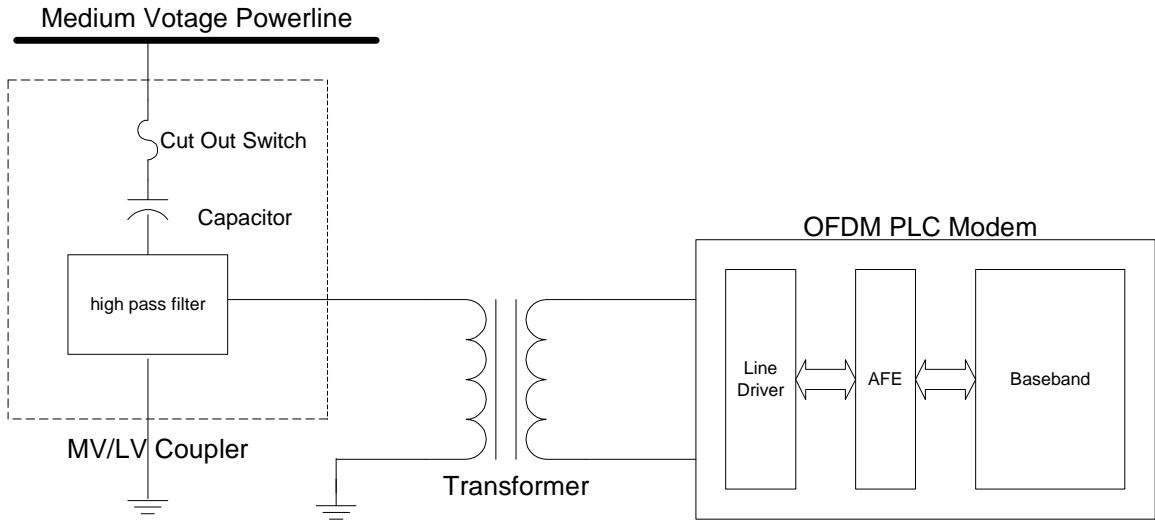

Figure 13- Proposed coupling circuit

5.15.1. COUPLER TECHNICAL CHARACTERISTICS

Parameter	Measurement conditions	Value
	Medium voltage circuit parameters	
Primary test voltage U_N	Voltage between the device input and grounding output	$24/\sqrt{3}$ kV _{RMS}
Test short-term alternating voltage U_{TH}	Voltage between the device input and grounding output during 1min.	50 kV rms
Maximum short-term working voltage. U_{MAX}	High Voltage during 9 Hours	26 kV _{RMS} 9 hours
Test lightning impulse voltage U_L	Impulse with duration of 1,2/50 us between the device input and the grounding output	125 kV
Partial discharge level		≤ 20 pC
Ambient temperature during operation		-40°-- +65°
Coupling capacitor capacity C_c	$-40^\circ\text{C} < T_a < +70^\circ\text{C}$	1.5 -13 nF
Fuse operate time max	at $I \geq 30\text{A}$ at $I \geq 45\text{A}$	$t \leq 100$ ms $t \leq 10$ ms

	Low voltage circuit parameters	
Nominal line side impedance R_{LINE}		$75\Omega \leq R \leq 170\Omega$
Nominal equipment side impedance R_{LOAD}		75Ω
Maximum operating attenuation in receive and transmit direction at $R_{LOAD} = 75 \Omega$, $R_{LINE} = 170 \Omega$	$35 \text{ kHz} \leq f \leq 170 \text{ kHz}$	3 dB

5.16. AC PHASE DETECTION

This is a basic approach to detect AC phase associated to a meter, however the optimal design would be dependent on the particular network topology. This information is mainly useful at system level in order to check for unexpected losses on the distribution line and must be stored in the MIB.

Three phases on the mains are sinusoidal waveforms with a phase shift of 120° from each other where each half cycle is equal to 10ms at 50Hz and 8.3 ms at 60Hz. A zero-crossing detector delivers an output pulse based on the signal transition through zero volt of a 50Hz sinusoidal on the power line, and is used to synchronize a Tx-meter and a Rx-meter. The Tx-meter generates a time stamp based on an internal counter at the instant a packet shall be transmitted. The receiver provides its own time stamp, and the delay between the Tx-meter and the Rx-meter provides the phase difference. The procedure to achieve the phase difference between transmitter and receiver is as follows.

1. All devices including meter and concentration shall have internal timers, which are synchronized to zero-crossing detector.
2. All devices shall have a zero-crossing detector that delivers an output pulse such that the pulse width is 5% of the total period. The characteristic of the zero crossing detector is shown in Figure 14.

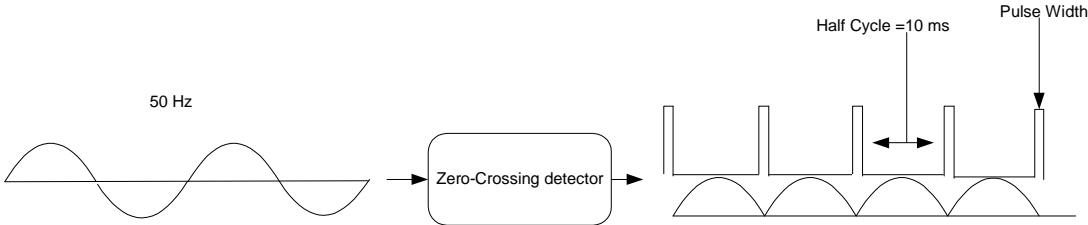

Figure 14- Zero Crossing Detector

3. An eight bits counter provides a time stamp placed on the FCH frame upon transmission of payload.

4. Upon detection of FCH frame, receiver shall compute the delay, which is the deference between transmit counter and received counter. The phase differential shall be computed shown below.

$$\text{Phase differential} = (\text{Rx_counter} - \text{Tx_Counter}) / 3$$

Electromagnetic propagation time and additional delay for packet processing and detection shall be considered measuring delay. Electromagnetic propagation delay is 5.775us/km, which can be neglected; however, a proceesing delay shall be factored into equation above as follows.

$$\text{New_Phase differential} = (\text{Rx_counter} - \text{detection_delay}) - (\text{Tx_Counter} - \text{trasmission_delay}) / 3$$

6. TRANSMITTER ELECTRICAL SPECIFICATIONS

6.1. OUTPUT LEVEL MEASUREMENT

G3 PLC transmitter output level shall be compliant with EN50065-1 where the level is measured with a peak detector with 200 Hz bandwidth, no part of the spectrum of the signal shall exceed 120 dB μ V.

6.2. TRANSMIT SPECTRUM MASK

PLC G3 PHY is provisioned to have programmable notches at certain frequencies in order to:

- a) Avoid certain frequencies that are reserved by powerline regulatory bodies for other applications.
- b) Allow cohabitation with S-FSK systems in compliance with IEC 61334-5-1.
- c) Allow inter-operability with other potential systems operating on powerline.

The transmitter shall use an appropriate scheme to insert deep notches in the spectrum. In particular, two frequencies referred to in the IEC 61334-5-1 standard as mark and space frequencies f_M and f_S , shall be notched in order to cohabitate with S-FSK systems.

Depending on the relative position of required notch frequency with respect to sub-carriers, a few sub-carriers are masked. No data is sent over the masked sub-carriers. According to the figure below, if the notch frequency is in the R1 region, SC(n-1), SC(n) and SC(n+1) are masked (total three sub-carriers). If the notch frequency is in the R2 region the two nearest sub-carriers in either side (i.e. SC(n-1), SC(n), SC(n+1) and SC(n+2)) are masked (a total of four sub-carriers).

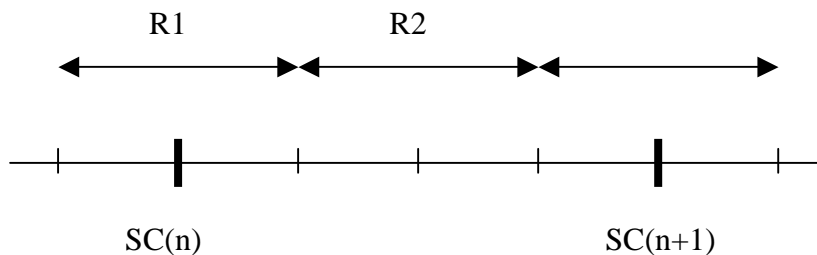

The notching map should be a Global parameter that is set in the initialization step of the devices. As described above, to provide sufficiently deep notches for a particular frequency band, it is required to zero one (or sometimes two) extra sub-carriers before and after that band, depending on the position of the Notch with respect to the sub-carriers. The following pseudo code can be used for the decision between one/two extra sub-carriers.

```
if NotchFreq / SamplingFreq * FFTSize is in R1
    Sc(n-1) = Sc(n) = Sc(n+1) = 0;
```

if $\text{NotchFreq} / \text{SamplingFreq} * \text{FFTSize}$ is in R2
 $\text{Sc}(n-1) = \text{Sc}(n) = \text{Sc}(n+1) = \text{Sc}(n+2) = 0;$

SamplingFreq and FFTSize are 400KHz and 256 respectively.

Sc is an array that determines which sub-carriers are used to transmit data (if Sc(i) is zero, no data is sent using that sub-carrier).

Frequency Notching reduces the number of active tones that are used for transmitting information. Since notching is done for all the transmit signals, including the Frame Control (FC) data, the number of symbols in FC depends on the number of active tones.

The following piece of code can determine the number of OFDM symbols that are used for transmitting the 33-bit FC

```
fcSize = 33; // Size of FC
rxFCSymNum = ceil( ( ( fcSize + 6 ) * 2 * 6 ) / freqNum );
```

freqNum is the number of available sub-carriers after frequency notching and ceil is the ceiling function.

In order to have minimum effect on S-FSK, the OFDM modem shall not transmit any signal in between S-FSK frequencies i.e. in 63Khz to 74 Khz band. The notched subcarriers in this mode are shown in Table 14.

Table 14- Notched subcarriers in cohabitation mode

Sub-carrier Number	Frequency of the Sub-carrier
39	60.9375
40	62.5000
41	64.0625
42	65.6250
43	67.1875
44	68.7500
45	70.3125
46	71.8750
47	73.4375
48	75.0000
49	76.5625

Therefore 11 sub-carriers cannot transmit data. Considering the fact that there are a total of 36 carriers available, 25 sub-carriers remain for data transmission, resulting in FC with 19 OFDM symbols because $\text{ceil}((33 + 6) * 2 * 6 / 25) = 19$.

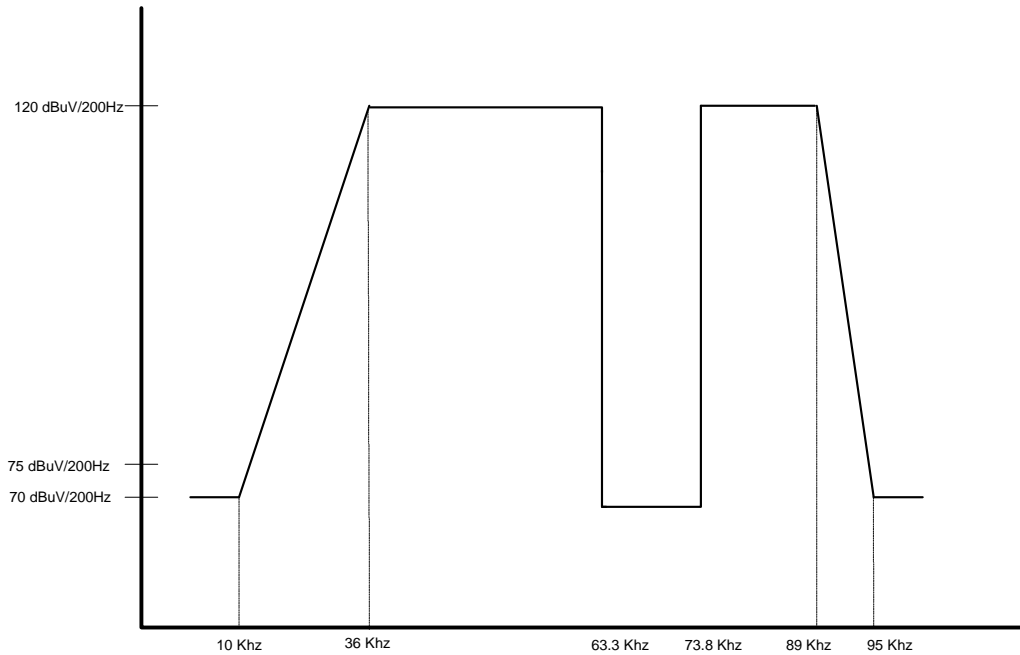

Figure 15- Spectrum with two notches inserted to cohabitate with S-FSK PLC modem

All stations shall use tone masking on the carriers specified in each substation in order to be compliant with the transmit spectrum mask. The transmitted power spectral density of notched frequency shall be 25 dB below the limits specified for rest of the sub carriers.

Measurements are made using a spectrum analyzer with a resolution bandwidth of 200 Hz and a quasi-peak detector. The transmitter shall be configured to repeatedly transmit maximum length rolling data pattern packets.

6.3. SPURIOUS TRANSMISSION

It is the obligation of the manufacturer to ensure that spurious transmissions conform to regulations in effect for the country in which this station is used.

6.4. SYSTEM CLOCK FREQUENCY TOLERANCE

The system clock tolerance shall be ± 25 ppm maximum. The transmit frequency and symbol timing shall be derived from the same system clock oscillator.

6.5. TRANSMIT CONSTELLATION ACCURACY

6.5.1. TRANSMIT CONSTELLATION ERROR

The relative constellation rms error, averaged over all subcarriers in a symbol, and averaged over several OFDM symbols, shall not exceed -15 dB from the ideal signal rms level.

6.5.2. TRANSMIT MODULATION ACCURACY TEST

The transmit modulation accuracy test shall be performed by instrumentation capable of converting the transmitted signal into a stream of samples at 400 k samples per second or more, with sufficient accuracy in terms of amplitude, DC offsets, and phase noise. The sampled signal shall be processed in a manner similar to an actual receiver, according to the following steps, or an equivalent procedure:

- a) Pass a sequence of 88 bytes all ones, representing a 12-symbol QPSK frame, through an ideal float-point sub-transmitter, for example using matlab, and save the complex IFFT input for each of the 12 data symbols as $A_{ic} \exp[j\Phi_{ic}]$, where i is the symbol number and c is the carrier number corresponding to that symbol. ' i ' will have values between 0 and 11 while c will be between 0 and 69. The ideal sub-transmitter should include all the transmitter blocks specified in this standard, including scrambler, forward error correction, interleaver, and mapper.
- b) Next, use the transmitter under test to generate the same frame using the bits specified in step a.
- c) Connect the test equipment that will simulate the receiver directly to the transmitter to detect start of frame.
- d) Save all 12 data symbols of the frame.
- e) Offline, apply a float point FFT on each symbol and store the complex values as $B_{ic} \exp[j\theta_{ic}]$ where i is the symbol number and c is the carrier number corresponding to that symbol.
- f) Compute the rms error between the transmitted and ideal constellation points for each symbol as the sum of the squared Euclidean distance between the two points over all the carriers in the symbol:

$$\text{error_rms}_i = \sum_{c=0}^{69} \text{abs}\{A_{ic} * \exp[j\Phi_{ic}] - B_{ic} * \exp[j\theta_{ic}]\}^2$$

Next compute the total rms error as the sum of the rms errors of the individual symbols:

$$\text{total error rms} = \sum_{i=0}^{11} \text{error_rms}_i$$

- g) Compute the rms of each transmitted symbol as:

$$\text{Tx_rms}_i = \sum_{c=0}^{69} A_{ic}^2$$

and the total rms for all transmitted symbols as:

$$\text{total Tx rms} = \sum_{i=0}^{11} \text{Tx_rms}_i$$

- h) Total error rms should satisfy the following equation:

$$20 * \log_{10}(\text{total error rms} / \text{total Tx rms}) < -15 \text{ dB}$$

6.6. TRANSMITTER SPECTRAL FLATNESS

No individual carrier shall have average power outside of the range +/- 2 dB with respect to the average power in all of the carriers as measured into a 50 Ohms impedance.

7. PHY PRIMITIVES

7.1. DATA PRIMITIVE

The receipt of the PD-DATA.request primitive by the PHY entity will cause the transmission of the supplied PSDU to be attempted. The PHY will first construct a PPDU, containing the supplied PSDU, and then transmit the PPDU. When the PHY entity has completed the transmission, it will issue the PD-DATA.confirm primitive with a status of SUCCESS. If the PD-DATA.request primitive is received while the receiver is enabled (RX_ON state), the PHY entity will discard the PSDU and issue the PD-DATA.confirm primitive with a status of FAILED. If the PD-DATA.request primitive is received while the transmitter is already busy transmitting (BUSY_TX state), the PHY entity will discard the PSDU and issue the PD-DATA.confirm primitive with a status of BUSY_TX.

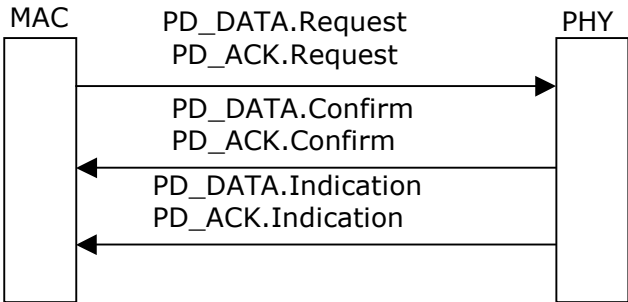

Figure 16- Data or ACK Primitive flow

7.1.1. PD-DATA.REQUEST

The PD-DATA.request primitive is generated by a local MAC sublayer entity and issued to its PHY entity to request the transmission of an MPDU.

The semantics of the PD-DATA.request primitive is as follows:

```

PD-DATA.request (
    psduLength
    psdu
)
    
```

Table 15 specifies the parameters for the PD-DATA.request primitive.

Table 15- The parameters for the PD-DATA.request primitive

Name	Type	Valid range	Description
------	------	-------------	-------------

psduLength	Integer	0x00-0x190	The number of bytes contained in the PSDU to be Transmitted by the PHY entity.
psdu	Integer	-----	The set of bytes forming the PSDU request to transmit by the PHY entity.

7.1.2. PD-DATA.CONFIRM

The PD-DATA.confirm primitive confirms the end of the transmission of an MPDU (i.e., PSDU) from a local PHY entity to a peer PHY entity. The semantics of the PD-DATA.confirm primitive is as follows:

```
PD-DATA.confirm (
    status
)
```

Table 16 specifies the parameters for the PD-DATA.confirm primitive.

Table 16- The parameters for the PD-DATA.confirm primitive

Name	Type	Valid range	Description
Status	Enumeration	SUCCESS, FAILED	The result of the request to transmit a packet.

7.1.3. PD-DATA.INDICATION

The PD-DATA.indication primitive indicates the transfer of an MPDU (i.e., PSDU) from the PHY to the local MAC sublayer entity. The semantics of the PD-DATA.indication primitive is as follows:

```
PD-DATA.indication (
    psduLength,
    psdu,
    ppduLinkQuality
)
```

Table 17 specifies the parameters for the PD-DATA.indication primitive.

Table 17- The parameters for the PD-DATA.indication primitive

Name	Type	Valid range	Description
psduLength	Integer	Maximum = 0x190	The number of bytes contained in the PSDU Received by the PHY entity.
psdu	Integer	-----	The set of bytes forming the PSDU received by the PHY entity.
ppduLinkQuality	Integer	0x00-0xFF	Link quality (LQI) value measured during reception of the PPDU

7.1.4. PD-ACK.REQUEST

The PD-ACK.Request primitive requests to send ACK frame to the PHY from the local MAC sub layer entity. The semantics of the PD-ACK.Request primitive is as follows:

PD-ACK.Request (
 FCH
)

Table 18 specifies the parameter for the PD-ACK.Request primitive.

Table 18- The parameter for the PD-ACK.Request primitive

Name	Type	Valid range	Description
FCH		Section 5.5 PHY	MAC layer provides all Frame Control Header parameters described in section 0 to construct FCH frame for ACK.

7.1.5. PD-ACK.CONFIRM

The PD-ACK.Confirm confirms the end of the transmission of an ACK packet. The semantics of the PD-ACK.Confirm primitive is as follows:

PD-ACK. Confirm (
 Status
)

Table 19 specifies the parameter for the PD-ACK.Confirm primitive.

Table 19- The parameters for the PD-ACK.Confirm primitive

Name	Type	Valid range	Description
Status	Enumeration	SUCCESS TXBUSY	Confirm transmission of ACK frame.

7.1.6. PD-ACK.INDICATION

The PD-ACK.indication primitive indicates reception of ACK frame from the PHY to the local MAC sublayer entity. The semantics of the PD-ACK.indication primitive is as follows:

PD-DATA.indication (FCH)

Table 20 specifies the parameter for the PD-ACK.Indication primitive.

Table 20- The parameters for the PD-ACK.Indication primitive

Name	Type	Valid range	Description
FCH		Section 5.5 PHY	MAC layer receives all Frame Control Header parameters described in section 0 from PHY layer.

7.2. MANAGEMENT PRIMITIVE

There are three types of management primitives, which are Get, Set and Confirm. They are used to initiate commends or retrieve data from Phy. PLME-SET.request function configures PHY to initial specific function. PLME-GET.request to retrieve specific parameters from PHY And PLME-xxx.confirm reports the result of an action initiated by MAC.

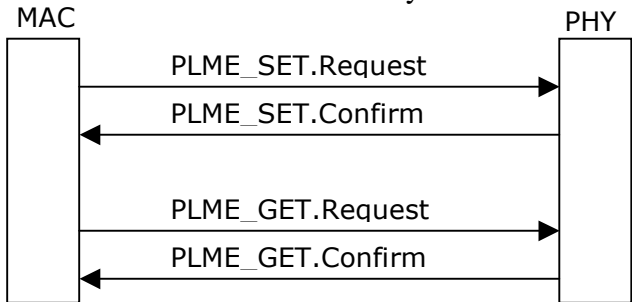

Figure 17- Management Primitive flow

7.2.1. PLME_SET.REQUEST

The semantics of the PLME-SET.Request primitive is as follows:

PLME_SET.Request (TXPower
AGCGain
ModulationType
ToneMap
PreEmphasis
ToneMask)

Table 21 specifies the parameters for the PLME-SET.Request primitive.

Table 21- The parameters for the PLME-SET.Request primitive

Name	Type	Valid range	Description
TXPower	Integer	0x00–0x20	MAC layer uses this primitive to notify PHY about the gain/power setting PHY has to use to transmit the next packet.
AGCGain	Integer	0x0–0x3F	MAC changes the AGC gain to a desired Energy level.
ModulationType	Integer	0x0-0x2	Set the TX modulation scheme for the next frame.
ToneMap	Array	0x0–0x1	Tone map parameter. The value of 0 indicates to the remote transmitter that dummy data should be transmitted on the corresponding sub carrier while a value of 1 indicates that valid data should be transmitted on the corresponding sub carrier.
PreEmphasis	Integer	0x00-0x1F	Specify transmit gain for each 10khz section of the available spectrum.
ToneMask	Array	0x0–0x1	Tone Mask parameter. The value of 0 indicates tone is notched 1 indicates that tone is enabled.

7.2.2. PLME_SET.CONFIRM

PHY stores new parameters and returns new stored value back to MAC layer. The semantics of the PLME-SET.confirm primitive is as follows:

```

PLME_SET.Request (
    TXPower
    AGCGain
    ModulationType
    ToneMap
    PreEmphasis
    ToneMask
)

```

Table 22 specifies the parameters for the PLME_SET.confirm primitive.

Table 22- The parameters for the PLME_SET.confirm primitive

Name	Type	Valid range	Description
TXPower	Integer	0x00–0x20	Returns new stored value back to MAC
AGCGain	Integer	0x00–0x3F	Returns new stored value back to MAC (optional)
ModulationType	Integer	0x0-0x2	Returns new stored value back to MAC

Table 26 specifies the parameters for the PLME_CS.Confirm primitive.

Table 26- The parameters for the PLME_CS.Confirm primitive

Name	Type	Valid range	Description
Status	Enumeration	IDLE BUSY	Powerline media status