

TOP VIEW

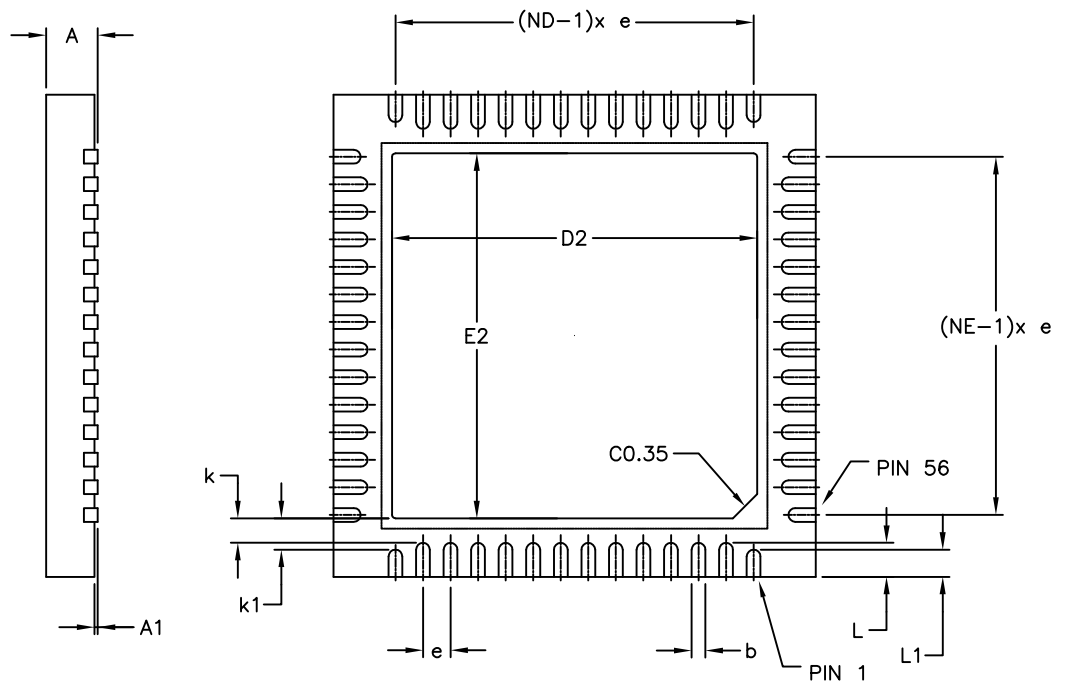

BOTTOM VIEW

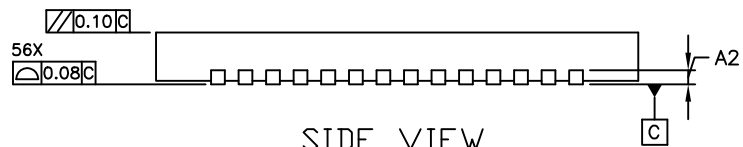

SIDE VIEW



PROPRIETARY INFORMATION

TITLE: PACKAGE OUTLINE, 56L THIN QFN  
 7x7x0.8mm BODY / 0.4mm LEAD PITCH

APPROVAL

DOCUMENT CONTROL NO.

REV.

21-0161

A

1/2

NOTES:



1. ALL DIMENSIONS ARE IN MILLIMETERS. ANGLES IN DEGREES.
2. COPLANARITY APPLIES TO THE EXPOSED PAD AS WELL AS THE TERMINALS. COPLANARITY SHALL NOT EXCEED 0.08mm.
3. WARPAGE SHALL NOT EXCEED 0.10mm.
4. PACKAGE LENGTH / PACKAGE WIDTH ARE CONSIDERED AS SPECIAL CHARACTERISTIC. (S)
5. REFER TO JEDEC MO-220.

6.  THE TERMINAL #1 IDENTIFIER AND TERMINAL NUMBERING CONVENTION SHALL CONFORM TO JESD 95-1 SPP-012. DETAILS OF TERMINAL #1 IDENTIFIER ARE OPTIONAL, BUT MUST BE LOCATED WITHIN THE ZONE INDICATED. THE TERMINAL #1 IDENTIFIER MAY BE EITHER A MOLD OR MARKED FEATURE.

7. ND AND NE REFER TO THE NUMBER OF TERMINALS ON EACH D AND E SIDE RESPECTIVELY.

COMMON DIMENSIONS			
SYMBOLS	MIN.	NOM.	MAX.
A	0.700	0.750	0.800
A1	0.000	-- --	0.050
A2	0.200 REF.		
b	0.150	0.200	0.250
D	6.900	7.000	7.100
e	0.400 TYP.		
E	6.900	7.000	7.100
k	0.250	0.350	0.450
k1	0.350	0.450	0.550
L	0.400	0.500	0.600
L1	0.300	0.400	0.500
N	56		
ND	14		
NE	14		

EXPOSED PAD VARIATONS						
PKG. CODE	D2			E2		
	MIN.	NOM.	MAX.	MIN.	NOM.	MAX.
T5677-1	5.20	5.30	5.40	5.20	5.30	5.40

 			
<small>PROPRIETARY INFORMATION</small>			
TITLE: PACKAGE OUTLINE, 56L THIN QFN 7x7x0.8mm BODY / 0.4mm LEAD PITCH			
APPROVAL	DOCUMENT CONTROL NO. <b>21-0161</b>	REV. <b>A</b>	<b>2/2</b>