

6

5

4

3

2

1

REVISION RECORD			
LTR	ECO NO:	APPROVED:	DATE:

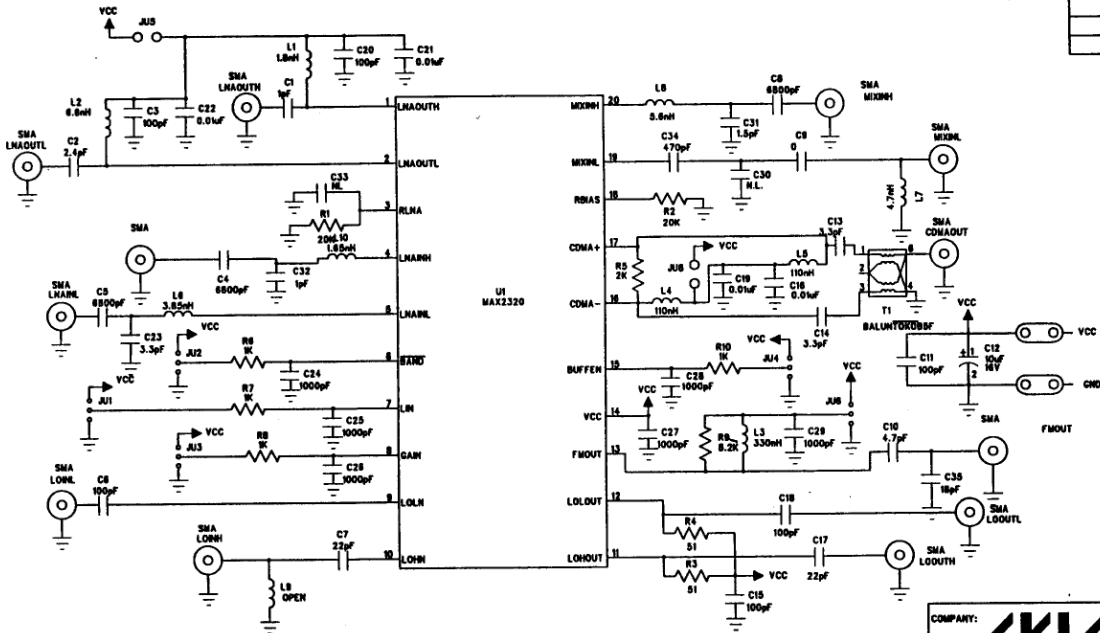

COMPANY:



TITLE:

MAX2320 EVALUATION KIT

CODE:

SIZE:

DRAWING NO:

REV:

B

SCALE:

SHEET: OF