

New Sequencing, Monitoring, and Tracking Solutions Provide Highest Integration and Design Flexibility

Highest Accuracy—Up to 1% Threshold Accuracy

Highest Integration—Sequence/Monitor/Track Up to Eight Voltages

Most Flexible—Configure Combinations of Sequencing and Tracking

SEQUENCING

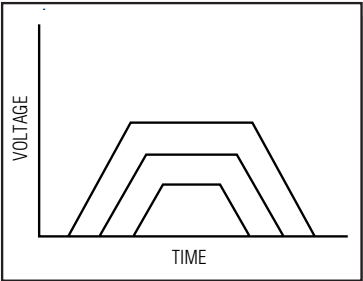

- Octal-Voltage, I²C** - Configurable Sequencer (MAX6889)
- Hex-Voltage, I²C-Configurable Sequencer/Supervisor with ADC and EEPROM (MAX6870)
- Dual-/Triple-Voltage Sequencers (MAX6880* - MAX6883*)
- Dual +13V, Hot-Swap, Power-Supply Sequencers (MAX5918/MAX5919)

MONITORING

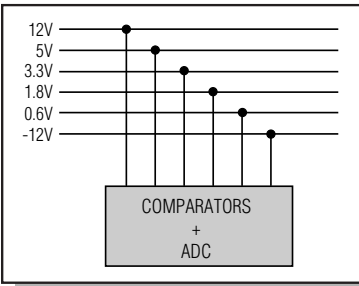

- Octal-Voltage, Pin-Selectable μP Supervisor (MAX6892)
- Hex-Voltage μP Supervisor with 10-Bit ADC (MAX6884)
- Hex-Voltage, Pin-Selectable μP Supervisor with WDI, MR (MAX6886)
- Hex-Voltage, OV/UV Monitor with Fixed Thresholds (MAX6887*)

TRACKING

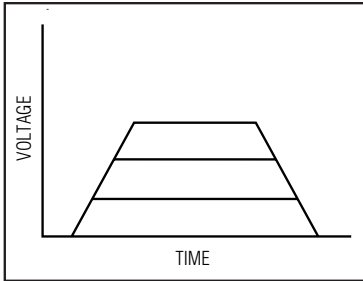

- Quad-Voltage, I²C-Configurable Tracker/Sequencer (MAX6876)
- Dual-/Triple-Voltage, Trackers/Sequencers (MAX6877*/MAX6878*/MAX6879*)
- Dual-Voltage, Shunt Trackers (MAX5039/MAX5040)
- Quad +13V, Hot-Swap, Power-Supply Tracker/Sequencer (MAX5927)

**Purchase of I²C components from Maxim Integrated Products, Inc., or one of its sublicensed Associated Companies, conveys a license under the Philips I²C Patent Rights to use these components in an I²C system, provided that the system conforms to the I²C Standard Specification defined by Philips.

*Future product—contact factory for availability.

The Maxim logo is a registered trademark of Maxim Integrated Products, Inc. The Dallas Semiconductor logo is a registered trademark of Dallas Semiconductor Corp.

© 2005 Maxim Integrated Products, Inc. All rights reserved.



EEPROM-Configurable Voltage Tracker/Sequencer Solves Complex Startup Requirements

Programmable Power-Up and Power-Down Operation Provides Maximum Design Flexibility in Telecom, Networking, and Storage Equipment

CONTACT FACTORY FOR EV KIT AND GUI TO SIMPLIFY PROGRAMMING

MAX6876 Beats the Competition Three Ways

- 1 Lowest Total System Cost—Independent Charge Pumps for Each Channel Allow the Use of Small, Low-Cost, Logic-Level MOSFETs
- 2 Smallest Package—TQFN Saves 55% Board Space
- 3 Lowest Voltage—Track Voltage Rails as Low as 0.5V (and Up to 5.5V)

Maximize Design Flexibility

- Sequence, Track, or Mixed-Mode (Sequence Plus Tracking) Operation
- I²C-Configurable Undervoltage/Overvoltage (UV/OV) Thresholds, Slew Rate, Output Faults, and Timeout Delays
- Combine Up to 4 Devices to Track Up to 16 Voltages

CLOSED-LOOP CONTROL ENSURES RELIABLE TRACKING

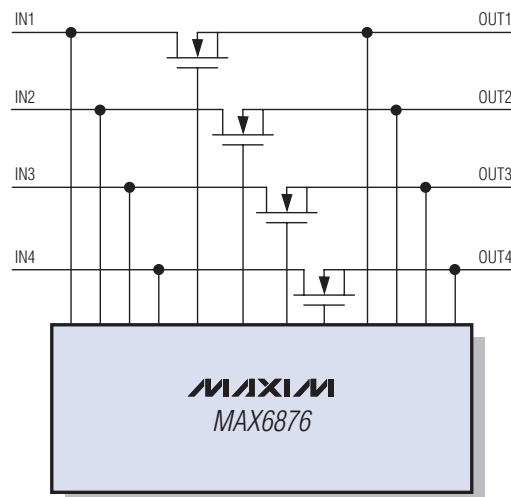

PROGRAM ANY COMBINATION OF TRACKING AND SEQUENCING DURING POWER-UP OR POWER-DOWN

TRACK VOLTAGES

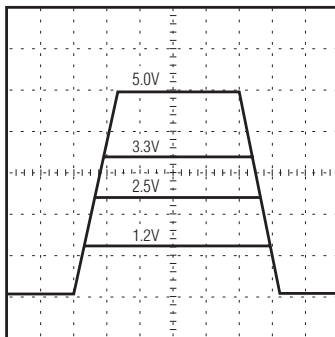

SEQUENCE VOLTAGES

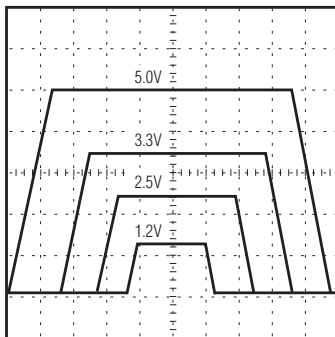

TRACK AND SEQUENCE VOLTAGES

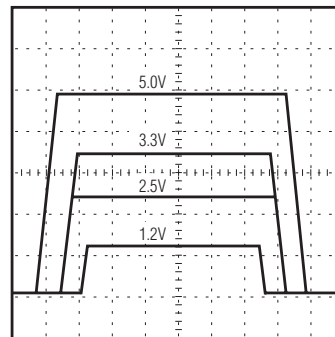



Dual/Triple Power-Supply Tracker/Sequencers Simplify Design, Decrease Overall Cost

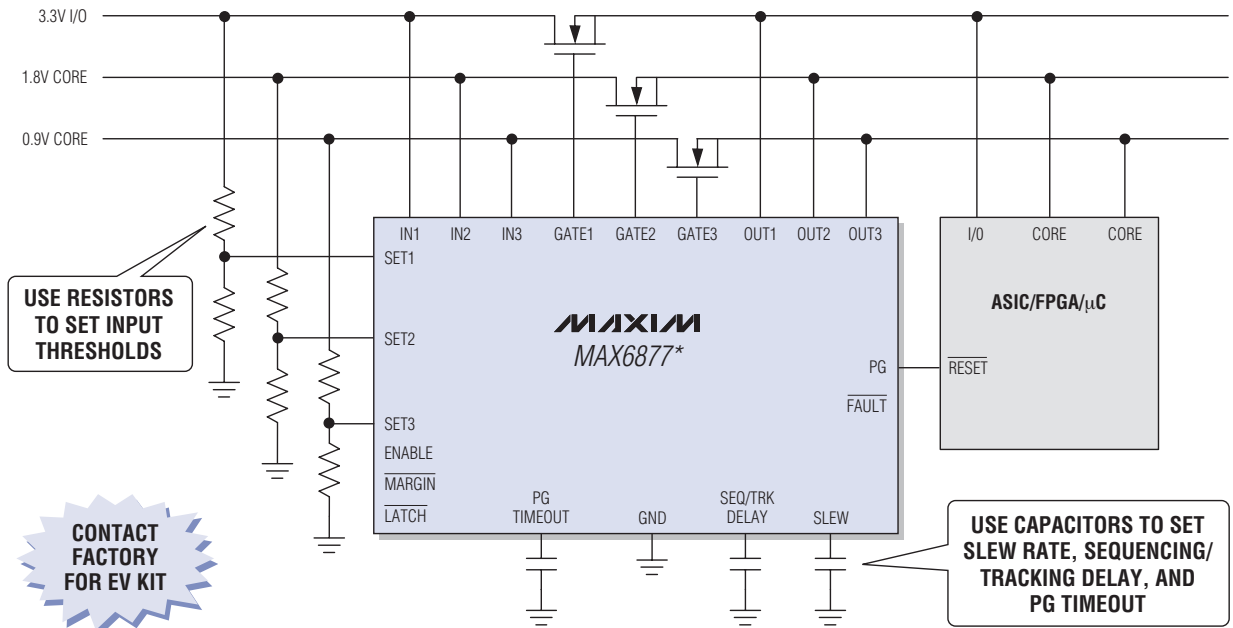

Beats the Competition Four Ways

- 1 **Lower Total System Cost**
 - Independent Charge Pumps for Each Channel Allow Use of Small, Low-Cost, Logic-Level MOSFETs
- 2 **More Features**
 - Margin Input, Enable Input, Latch or Autoretry on Tracking Fault
- 3 **More Flexible**
 - Track/Sequence Power-Supply Rails
 - Adjustable Input Thresholds, Slew Rate, Sequencing/Tracking Delay, and Power Good/Reset Timeout
- 4 **Smaller**
 - 4mm x 4mm Package Saves Board Space

TRACK UP TO THREE VOLTAGES ON POWER-UP AND POWER-DOWN

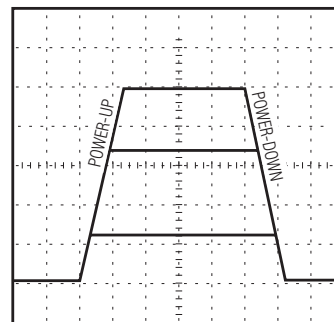

Part	No. of Voltages	Track or Sequence	PG Output	Margin Input	Latch/Autoretry
MAX6877*	3	Track or sequence	✓	✓	✓
MAX6878*	2	Track or sequence	✓	✓	✓
MAX6879*	2	Track or sequence			✓
MAX6880*	3	Sequence only	✓	✓	
MAX6881*	3	Sequence only			
MAX6882*	2	Sequence only	✓	✓	
MAX6883*	2	Sequence only			

*Future product—contact factory for availability.





World's First Hex-Voltage, Pin-Selectable μ P Supervisor with 1% Threshold Accuracy

WHY USE SIX OF THESE...

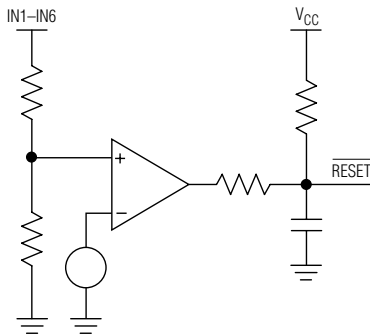

WHEN YOU CAN USE JUST ONE OF THESE?

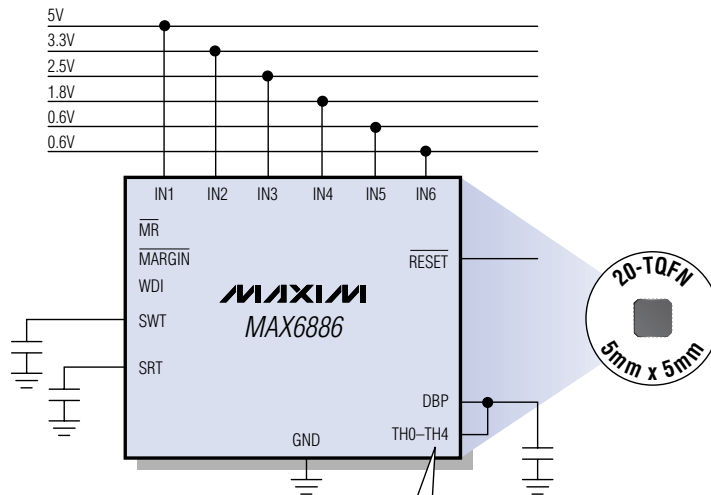

FIVE LOGIC INPUTS FOR SELECTING 32 THRESHOLD COMBINATIONS (MAX6886); FIXED THRESHOLD VERSIONS ALSO AVAILABLE (MAX6887/MAX6888)

- **High Accuracy**—1% Threshold Accuracy
- **Flexible**—Capacitor-Adjustable Reset and Watchdog Timeouts
- **Low Voltage**—Monitor Down to 0.6V
- **Additional Features**— $\overline{\text{MR}}$, $\overline{\text{MARGIN}}$, and Overvoltage Monitoring (MAX6887/MAX6888)

NEW

Part	Description	No. of Voltages Monitored	Watchdog Input	Watchdog Output	Overvoltage Output
MAX6886	Pin-selectable, hex μ P supervisor	6	✓		
MAX6887*	Fixed-threshold, hex μ P supervisor	6	✓	✓	✓
MAX6888*	Fixed-threshold, quad μ P supervisor	4	✓	✓	✓

Cannot find what you need? Fill out a request form at www.maxim-ic.com/uprequest, or email us at superhelp@maximhq.com, for assistance in selecting the right μ P supervisor for your application.

*Future product—contact factory for availability.





Hex-Voltage, EEPROM-Configurable μ P Supervisor Integrates 10-Bit ADC

Accurate (1%) Voltage Readback for Predicting and Monitoring System Failures

CONTACT FACTORY FOR EV KIT AND GUI TO SIMPLIFY PROGRAMMING

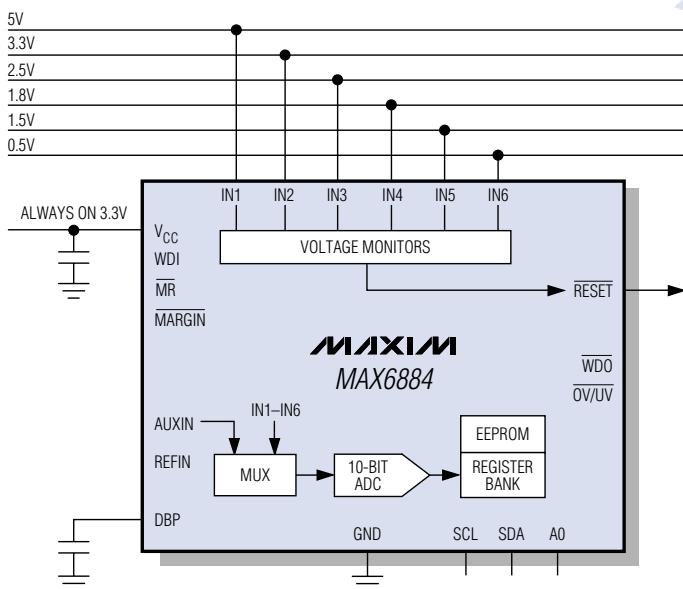

Configurable Voltage Monitoring

- 1% Accurate Thresholds from 0.5V to 5.8V in 10mV or 20mV Increments
- Dual Comparator Inputs for Overvoltage and Undervoltage Detection
- Timing Delays from 25 μ s to 1600ms
- Added Features— $\overline{\text{MR}}$, $\overline{\text{MARGIN}}$, and Watchdog Timer

10-Bit ADC

- Readback Supply Voltages Predict System Failures and Field Maintenance Requests
- ADC Total Unadjusted Error of $\pm 1\%$ FSR
- REFIN Pin for Greater ADC and Threshold Accuracy

Part	Description	Interface	No. of Voltages Monitored	ADC
MAX6884	I ² C-configurable, hex μ P supervisor with ADC	I ² C	6	✓
MAX6885	I ² C-configurable, hex μ P supervisor	I ² C	6	

For the Broadest Selection of μ P Supervisors, Visit:
www.maxim-ic.com/supervisors

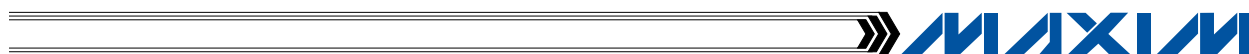



Octal/Hex/Quad Power-Supply Sequencer/Supervisors Control Complicated Power-Up/Down Requirements

MAXIMUM DESIGN FLEXIBILITY

EEPROM, I²C-Configurable Sequencer/Supervisors (MAX6889/MAX6890/MAX6891)

Key Benefits

- **Ultimate Design Flexibility with Configurable:**
 - Undervoltage Thresholds
 - Output Stage (Push-Pull, Open Drain)
 - Output Timeout (25µs to 1600ms)
 - Output Dependency
 - Watchdog Function
 - Save Configurations in EEPROM
- **Integration—Octal/Hex/Quad Voltage Monitors in One IC**

Advantages over the Competition

- **More Features—MR, GPI, and MARGIN for Better Control**
- **More Outputs to Control More DC-DC Converters**
- **Small, 5mm x 5mm TQFN Saves Board Space**

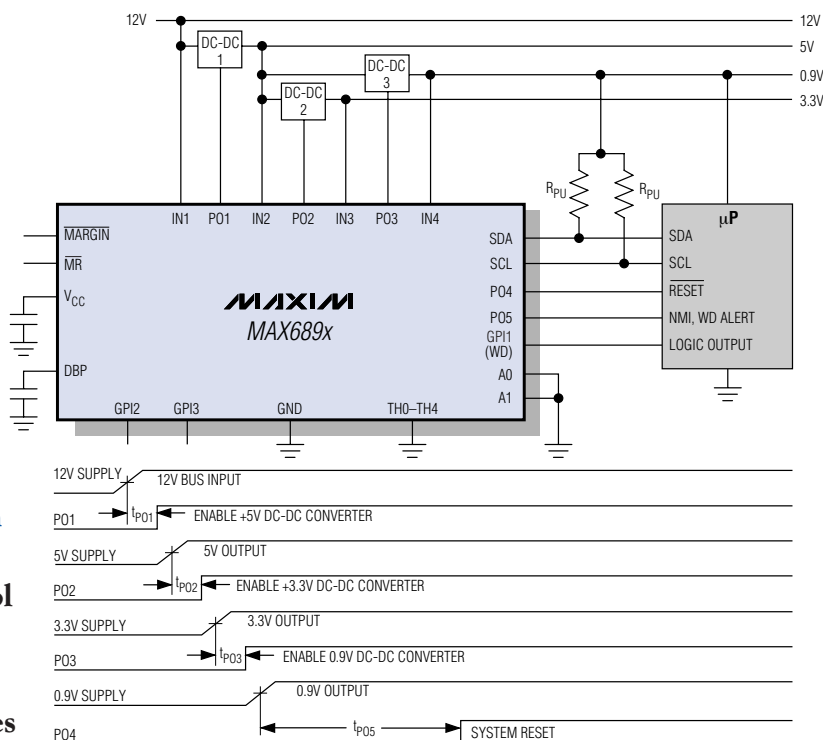

Part	Description	No. of Voltages Monitored	No. of Outputs	High-Voltage Input	Manual-Reset Input	MARGIN Input	GPI
MAX6889	I ² C-configurable, octal sequencer/supervisor	8	10	✓	✓	✓	4
MAX6890	I ² C-configurable, hex sequencer/supervisor	6	8	✓	✓	✓	4
MAX6891	I ² C-configurable, quad sequencer/supervisor	4	5	✓	✓	✓	3

**Have an idea for a new supervisory/system management device?
Contact us at superhelp@maximhq.com**



Octal/Hex/Quad Power-Supply Sequencer/Supervisors Control Complicated Power-Up/Down Requirements



Pin-Selectable Sequencer/Supervisors (MAX6892/MAX6893/MAX6894)

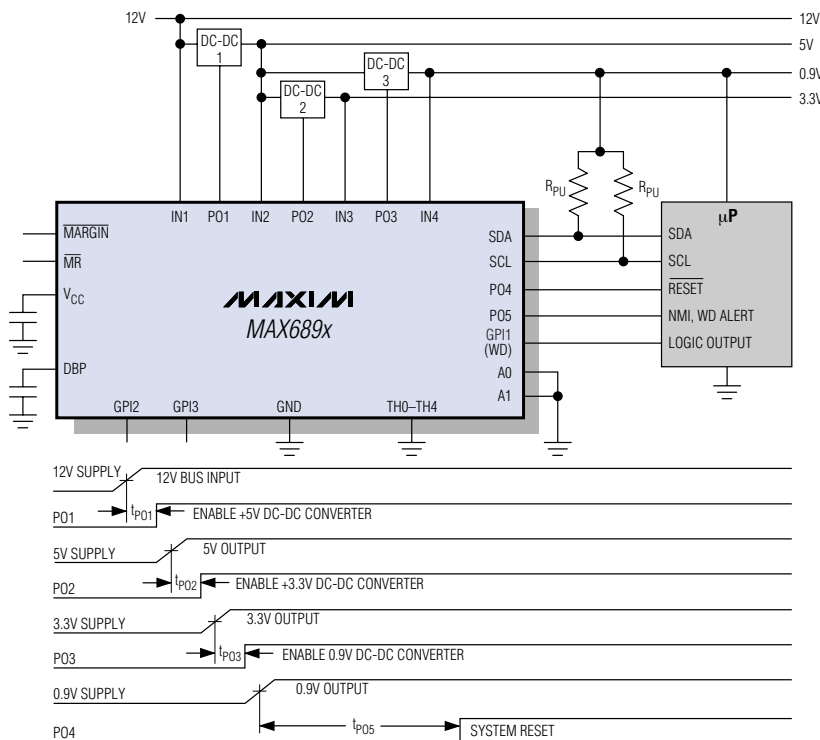

Key Benefits

- **Ease of Use**—Simple, Hardwired Voltage Monitoring/Sequencing Function
- **Flexibility**
 - 32 Pin-Selectable Configurations Using TH0–TH4
 - Capacitor-Adjustable RESET and Watchdog Timeouts
- **Integration**—Octal-/Hex-/Quad-Voltage Monitors in One IC

Advantages over the Competition

- **Better Accuracy**— $\pm 1\%$ Threshold Accuracy Improves Reliability
- **More Threshold Options**—32 Pin-Selectable Configurations for Greater Flexibility
- **More Outputs to Control More DC-DC Converters**
- **Small, 5mm x 5mm TQFN Saves Board Space**

Part	Description	No. of Voltages Monitored	No. of Outputs
MAX6892	Pin-selectable, octal sequencer/supervisor	8	10
MAX6893	Pin-selectable, hex sequencer/supervisor	6	8
MAX6894	Pin-selectable, quad sequencer/supervisor	4	6

Have an idea for a new supervisory/system management device?
Contact us at superhelp@maximhq.com



Low-Voltage, Dual Hot-Swap Controllers for +1V to +13.2V Rails

Independent On/Off Control Allows Power-Supply Sequencing

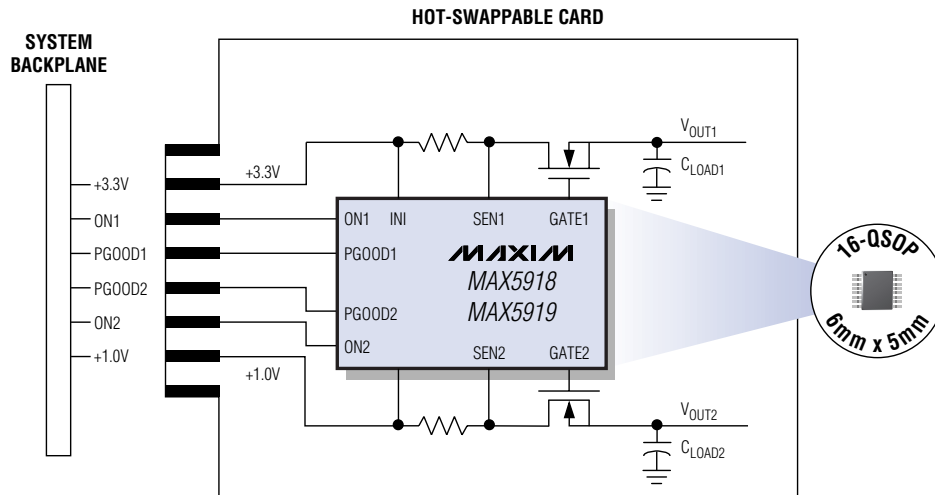

Beat the Competition Four Ways

Parameter	Competition	MAX5918/MAX5919	Maxim Advantage
Input voltage range (V)	+1.7 to +16.5	+1 to +13.2	Meets low-voltage requirements for next-generation systems.
Circuit-breaker threshold (mV)	50	25	Improves system efficiency; reduces voltage drop headroom.
VariableSpeed/BiLevel™ fault protection	No	Yes	1) Prevents nuisance trips due to system noise and load transients. 2) Improves system reliability by providing a fast response to excessive load current and short-circuit conditions.
Adjustable circuit-breaker/current-limit threshold	No	Yes	Fine-tunes current-limit threshold for use with standard-value sense resistors.



Part	Output UV/OV Protection/Monitoring	Fault Management	Package
MAX5918	Protection: turns off MOSFET	Autoretry/latched	16-QSOP
MAX5919	Monitoring: reports fault	Autoretry/latched	16-QSOP

For a Complete Selection of Hot-Swap Controllers, Visit:
www.maxim-ic.com/hotswap

VariableSpeed/BiLevel is a trademark of Maxim Integrated Products, Inc.



Triple/Quad Hot-Swap ICs for +1V to +13.2V Supplies

Allow Sequencing, Tracking, or Independent On/Off Control

YOUR BEST CHOICE FOR THREE REASONS

1 SUPERIOR FAULT PROTECTION

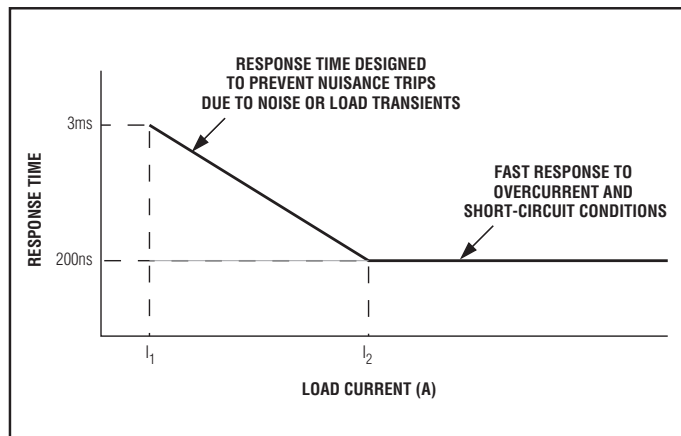

2 CONFIGURABLE FOR VOLTAGE TRACKING OR POWER SEQUENCING

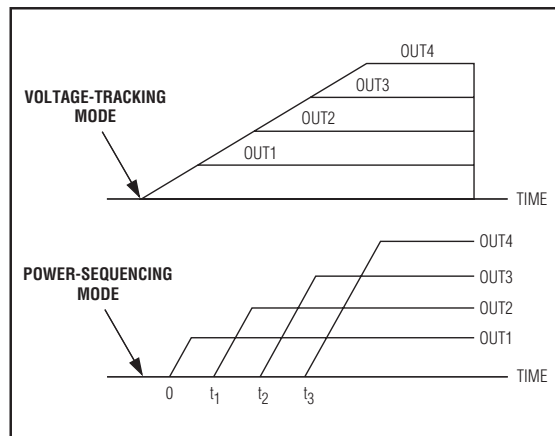

3 MOST VERSATILE

- Adjustable 25mV to 100mV Circuit-Breaker Threshold
- Selectable Latched or Autoretry Fault Management
- Programmable Undervoltage Lockout
- 0.4ms to 50ms Adjustable Startup Period
- Selectable Active-High or Active-Low Status Polarity
- Drive Low-Cost n-Channel MOSFETs

Part	No. of Inputs	Circuit-Breaker Threshold (mV)	Fault Management	Status Polarity
MAX5927	4	25 to 100 (adj)	Selectable: latched off or autoretry	Selectable: active low or active high
MAX5929	4	25	Latched off	Active high
MAX5930	3	25 to 100 (adj)	Selectable: latched off or autoretry	Selectable: active low or active high
MAX5931	3	25	Selectable: latched off or autoretry	Selectable: active low or active high

EV KIT AVAILABLE TO SPEED DESIGNS

EEPROM-Configurable Hex/Quad Sequencer Integrates Complete Monitoring Solution

25% Smaller and 2.5x Higher Accuracy (1%) than the Competition—
Ideal for Networking/Telecom, Base-Station, Server, and Storage Equipment

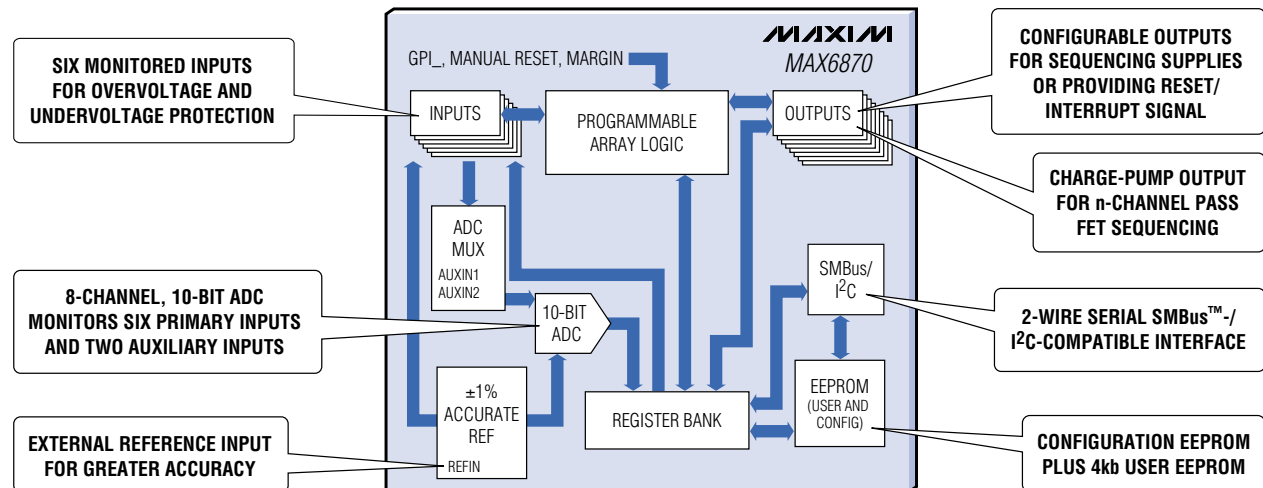

Programmable, Highly Flexible

- Configurable Thresholds with 10mV/20mV Increments
- High Voltage (+13.2V) and Bipolar Inputs ($\pm 15V$)
- Programmable Timing Options from 25 μ s to 1600ms
- Programmable Output Structures
- Auxiliary Inputs for Temperature/ Current Monitoring

Higher Integration and Accuracy

- 1% Threshold Accuracy
- ADC with Internal Registers for Readback Capability
- Out-of-Window Threshold Detection
- MARGIN Enable Input
- Configurable Write-Lock Protection

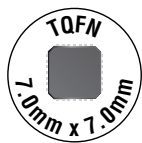

Part	Analog Inputs	ADC	Programmable Outputs (Open Drain and Push-Pull)
MAX6870/71	6/4	✓	8/5 (with charge pump)
MAX6872/73	6/4		8/5 (with charge pump)
MAX6874/75	6/4		8/5



SMBus is a trademark of Intel Corp.



Sequencers

Part	No. of Inputs	No. of Outputs	Configuration	Charge-Pump Output	ADC	Additional Features
MAX6889	8	10	I ² C			High-voltage input, \overline{MR} , \overline{MARGIN} , GPIs
MAX6892	8	10	Pin selectable			High-voltage input, \overline{ENABLE} input, \overline{MR} , \overline{MARGIN} , $\overline{WDI/WDO}$, capacitor-adjustable reset and watchdog timeouts
MAX6870	6	8	I ² C	✓	✓	High-voltage input, bipolar input, overvoltage detection, \overline{AUXIN} , \overline{MARGIN} , \overline{MR}
MAX6872	6	8	I ² C	✓		High-voltage input, bipolar input, overvoltage detection, \overline{MARGIN} , \overline{MR}
MAX6874	6	8	I ² C			High-voltage input, \overline{MARGIN} , \overline{MR}
MAX6890	6	8	I ² C			High-voltage input, \overline{MR} , \overline{MARGIN} , GPIs
MAX6893	6	8	Pin selectable			High-voltage input, \overline{ENABLE} input, \overline{MR} , \overline{MARGIN} , $\overline{WDI/WDO}$, capacitor-adjustable reset and watchdog timeouts
MAX6894	4	6	Pin selectable			High-voltage input, \overline{ENABLE} input, \overline{MR} , \overline{MARGIN} , $\overline{WDI/WDO}$, capacitor-adjustable reset and watchdog timeouts
MAX6871	4	5	I ² C	✓	✓	High-voltage input, bipolar input, overvoltage detection, \overline{AUXIN} , \overline{MARGIN} , \overline{MR}
MAX6873	4	5	I ² C	✓		High-voltage input, bipolar input, overvoltage detection, \overline{MARGIN} , \overline{MR}
MAX6875	4	5	I ² C			High-voltage input, \overline{MARGIN} , \overline{MR}
MAX6891	4	5	I ² C			High-voltage input
MAX6880*	3	1	Adjustable	✓		\overline{ENABLE} input, \overline{MARGIN} , \overline{PG} output, capacitor-adjustable delay, timeout, slow rate
MAX6881*	3	—	Adjustable	✓		\overline{ENABLE} input, capacitor-adjustable delay, slow rate
MAX6819	2	1	Adjustable	✓		\overline{ENABLE} input
MAX6820	2	1	Adjustable	✓		Capacitor-adjustable, GATE delay
MAX6882*	2	1	Adjustable	✓		\overline{ENABLE} input, \overline{MARGIN} , \overline{PG} output, capacitor-adjustable delay, timeout, slow rate
MAX6883*	2	—	Adjustable	✓		\overline{ENABLE} input, capacitor-adjustable delay, slow rate

Trackers

Part	No. of Inputs	Configuration	\overline{MARGIN} Input	PG Input	Additional Features
MAX6876	4	I ² C	✓	✓	Overcurrent detection, $\overline{UV/OV}$ detection, \overline{ENABLE} input, \overline{TRKEN} input, \overline{REFIN} input, track \overline{FAULT} output
MAX6877*	3	Adjustable	✓	✓	\overline{ENABLE} input, track \overline{FAULT} output, capacitor-adjustable delay, timeout, slow rate
MAX6878*	2	Adjustable	✓	✓	\overline{ENABLE} input, track \overline{FAULT} output, capacitor-adjustable delay, timeout, slow rate
MAX6879*	2	Adjustable			\overline{ENABLE} input, track \overline{FAULT} output, capacitor-adjustable delay, slow rate

Multivoltage Monitors

Part	No. of Inputs	No. of Outputs	Configuration	Watchdog Timer	UV/OV Output	ADC	Additional Features
MAX6892	8	10	Pin selectable	✓			High-voltage input, \overline{ENABLE} , \overline{MR} , \overline{MARGIN} , capacitor-adjustable reset and watchdog timeouts
MAX6893	6	8	Pin selectable	✓			High-voltage input, \overline{ENABLE} , \overline{MR} , \overline{MARGIN} , capacitor-adjustable reset and watchdog timeouts
MAX6884	6	3	I ² C	✓	✓	✓	\overline{MR} , \overline{MARGIN} , \overline{REFIN} , \overline{AUXIN}
MAX6885	6	3	I ² C	✓	✓		\overline{MR} , \overline{MARGIN}
MAX6887	6	3	Fixed/adjustable	✓	✓		\overline{MR} , \overline{MARGIN}
MAX6886	6	1	Pin selectable	✓			\overline{MR} , \overline{MARGIN} , capacitor-adjustable reset and watchdog timeouts
MAX6894	4	6	Pin selectable	✓			High-voltage input, \overline{ENABLE} , \overline{MR} , \overline{MARGIN} , capacitor-adjustable reset and watchdog timeouts
MAX6338	4	4	Fixed/adjustable	✓			Negative voltage monitoring
MAX6709/MAX6714	4	4	Fixed/adjustable				Low-voltage monitoring (0.62V ref), \overline{MR} , \overline{RESET}
MAX6888	4	3	Fixed/adjustable	✓	✓		\overline{MR} , \overline{MARGIN}
MAX6339	4	1	Fixed/adjustable				Negative voltage monitoring
MAX6700/MAX6710	4	1	Fixed/adjustable				Low-voltage monitoring (0.62V ref)

*Future product—contact factory for availability.