



## 68L11D Module

68L11D Module

### General Description

The 68L11D module is an assembled and tested PC board intended for use with Maxim's low-voltage data-acquisition evaluation kits (EV kits). The module uses Motorola's MC68L11D0FN2 microcontroller ( $\mu$ C) to collect data samples using the SPI interface. It requires an IBM PC computer and an external DC power supply of +5V to +16V, or as specified in the appropriate EV kit manual.

Maxim's 68L11D module allows customers to evaluate selected Maxim products. It is not intended to be a microprocessor development platform, and Maxim does not support such use.

### Getting Started

All system components are guaranteed by their various manufacturers over the +3V to +3.6V power-supply range. Not all system components are guaranteed over the entire 2.5V to 5V  $V_{DD}$  power-supply adjustment range. Verify correct operation using the following procedures:

- 1) Connect a +5V DC power source (16V max) to the  $\mu$ C module at the terminal block located next to the on/off switch, in the upper-right corner of the  $\mu$ C module. Turn the power switch on.
- 2) Connect a cable from the computer's serial port to the  $\mu$ C module. If using a 9-pin serial port, use a straight-through, 9-pin, female-to-male cable. If the only available serial port uses a 25-pin connector, a standard 25-pin to 9-pin adapter is required.
- 3) Start the evaluation kit software on the IBM PC. When the program asks which port the  $\mu$ C module is connected to, press the space bar until the correct port is highlighted, and then press ENTER. The software will be in terminal-emulation mode. (If using a generic terminal-emulation program instead of Maxim EV kit software, select 1200 baud, eight-bit character, no parity, one stop bit. Send a space character to start the monitor program.)
- 4) Adjust trim potentiometer R2 for the desired  $V_{DD}$  supply voltage. Measure  $V_{DD}$  between test point TP1 and ground. The mounting hole next to R2 is grounded.
- 5) To verify correct system operation, press the ESC key, type a capital "T", and then select the count-down memory test. If the memory test fails or any other malfunction is reported, the  $V_{DD}$  voltage is too low; increase  $V_{DD}$  and repeat from step 4.
- 6) Turn the power switch off and connect the  $\mu$ C board to an appropriate Maxim EV kit board.

### Component List

DESIGNATION	QTY	DESCRIPTION
C1, C2	2	22pF ceramic capacitors
C3	1	0.01 $\mu$ F ceramic capacitor
C4-C9, C12-C18	13	0.1 $\mu$ F ceramic capacitors
C10, C11	2	22 $\mu$ F, 20V tantalum capacitors
D1	1	1N4001 diode
J1	1	40-pin, right-angle header
J2	1	2-circuit terminal block
J3	1	DB9 right-angle socket
JU1, JU2	2	Open
LED1	1	Light-emitting diode
R1	1	10M $\Omega$ , 5% resistor
R2	1	100k $\Omega$ potentiometer
R3	1	274k $\Omega$ , 1% resistor
R4	1	133k $\Omega$ , 1% resistor
R5	1	200 $\Omega$ , 5% resistor
R6	1	10k $\Omega$ SIP resistor pack, pin 1 common
SW1	1	Slide switch
SW2	1	Momentary push-button switch
U1	1	Motorola MC68L11D0FN2
U2	1	Maxim MAX3232CSE
U3	1	74HC00
U4	1	Maxim MAX667CSA
U5	1	32k x 8 static RAM 28-pin socket Motorola MCM6306DJ15
U10	1	28-pin socket
U6	1	74HCT245
U7	1	Maxim MAX708RCSA
U8	1	74HC573
U9	1	74HC139
U10	1	3V, 8k x 8 ROM
Y1	1	8MHz crystal



# 68L11D Module

## Detailed Description

### Power Requirements

The 68L11D module draws its power from a user-supplied power source connected to terminal block J2. Note the positive and negative markings on the board. Nominal input voltages should be between +5V and +16V. The input current requirement for the 68L11D module is typically 20mA plus the current drawn by the evaluation kit (EV kit).

The  $V_{DD}$  supply is set by U4, a MAX667 low-dropout CMOS regulator. Trim potentiometer R2 sets the supply voltage, with an adjustment range of approximately 2.5V to 5V. Although the board is designed primarily for 3V applications, all of the circuitry is rated to withstand 5V levels.

### 68L11D Microcontroller ( $\mu$ C)

#### Module Hardware

U1 is Motorola's 68L11D  $\mu$ C. Contact Motorola for  $\mu$ C information, development, and support.

A MAX708R supervisory circuit on the module monitors the  $V_{DD}$  logic supply, generates the power-on reset, and produces a reset pulse whenever the manual reset button (SW2) is pressed. Note that the MAX708R resets the CPU if the supply voltage falls below 2.66V.

The module provides 32kbytes of external CMOS static RAM (U5).

The 74HCT245 octal buffer (U6) provides access to an eight-bit port on the 40-pin interface connector. This memory-mapped port consists of Intel-compatible read and write strobes, four chip selects, four address LSB's, and eight data bits. Table 3 lists the address ranges for each of the memory-mapped elements on the 68L11D module.

The MAX3232 is a 3V-powered, RS-232 interface voltage-level shifter. Its built-in charge pump uses external capacitors to generate the output voltages necessary to drive RS-232 lines.

The 20 x 2-pin header (J1) connects the 68L11D module to a Maxim EV kit. Table 2 lists the function of each pin. Use the 68L11D module only with EV kits that are designed to support it, and download only code that is targeted for the Maxim 68L11D module. Downloading incorrect object code into the 68L11D module will produce unpredictable results.

The 8k x 8 boot ROM (U10) checks the system and waits for commands from the host. Refer to the EV kit manual for specific startup procedures.

### Software

All software is supplied on a disk with the EV kit. Software operating instructions are included in the EV kit manual.

### Serial Communications

J3 is an RS-232 serial port, designed to be compatible with the IBM PC 9-pin serial port. Use a straight-through DB9 male-to-female cable to connect J3 to the IBM PC serial port. If the only available serial port has a 25-pin connector, use a standard 25-pin to 9-pin adapter. Table 1 shows J3's pinout. The hardware-handshake lines are used by the evaluation software to confirm that the EV kit is connected to the correct serial port.

**Table 1. Serial Communications Port J3**

PIN	NAME	FUNCTION
1	DCD	Handshake; hard-wired to DTR and DSR
2	RXD	RS-232-compatible data output from 68L11D module
3	TXD	RS-232-compatible data input to 68L11D module
4	DTR	Handshake; hard-wired to DCD and DSR
5	GND	Signal ground connection
6	DSR	Handshake; hard-wired to DCD and DTR
7	RTS	Handshake; hard-wired to CTS
8	CTS	Handshake; hard-wired to RTS
9	None	Unused

# 68L11D Module

68L11D Module

**Table 2. 40-Pin Data-Connector Signals**

PIN	NAME	FUNCTION
1-4	GND	Ground
5, 6	V <sub>++</sub>	Unregulated input voltage
7, 8	V <sub>DD</sub>	V <sub>DD</sub> from on-board MAX667 regulator
9	$\overline{RD}$	Read strobe
10	$\overline{WR}$	Write strobe
11	$\overline{CS0}$	Chip select for 8000-8FFF
12	$\overline{CS1}$	Chip select for 9000-9FFF
13	$\overline{CS2}$	Chip select for A000-AFFF
14	$\overline{CS3}$	Chip select for B000-BFFF
15	ADDR0	Address bit 0 (LSB)
16	ADDR1	Address bit 1
17	ADDR2	Address bit 2
18	ADDR3	Address bit 3
19	DB0	Data bus bit 0 (LSB)
20-26	DB1-DB7	Data bus bits 1-7
27	PA0/IC3	General I/O port bit 0 (LSB)
28	PA1/IC2	General I/O port
29	PA2/IC1	General I/O port
30	PA3/IC4/OC5	General I/O port
31	PA4/OC4	General I/O port
32	PA5/OC3	General I/O port
33	PA6/OC2	General I/O port
34	PA7/OC1/PAI	General I/O port MSB
35	MISO	SPI master-in, slave-out
36	MOSI	SPI master-out, slave-in
37	SCK	SPI serial clock
38	RESERVED	Reserved for factory use
39	E	System E-clock output
40	$\overline{SS}$	SPI slave-select input

**Table 3. 68L11D Module Memory Map**

ADDRESS RANGE (HEX)	FUNCTION
0000-7FFF	User RAM area (U5)
8000-8FFF	External chip-select 0 (J1 pin 11)
9000-9FFF	External chip-select 1 (J1 pin 12)
A000-AFFF	External chip-select 2 (J1 pin 13)
B000-BFFF	External chip-select 3 (J1 pin 14)
C000-C03F	Unused
C040-C0FF	Internal RAM (U1)
C100-CFFF	Unused
D000-D03F	Internal register area (U1)
D040-DFFF	Unused
E000-FFFF	Boot ROM (U10)

# 68L11D Module

68L11D Module

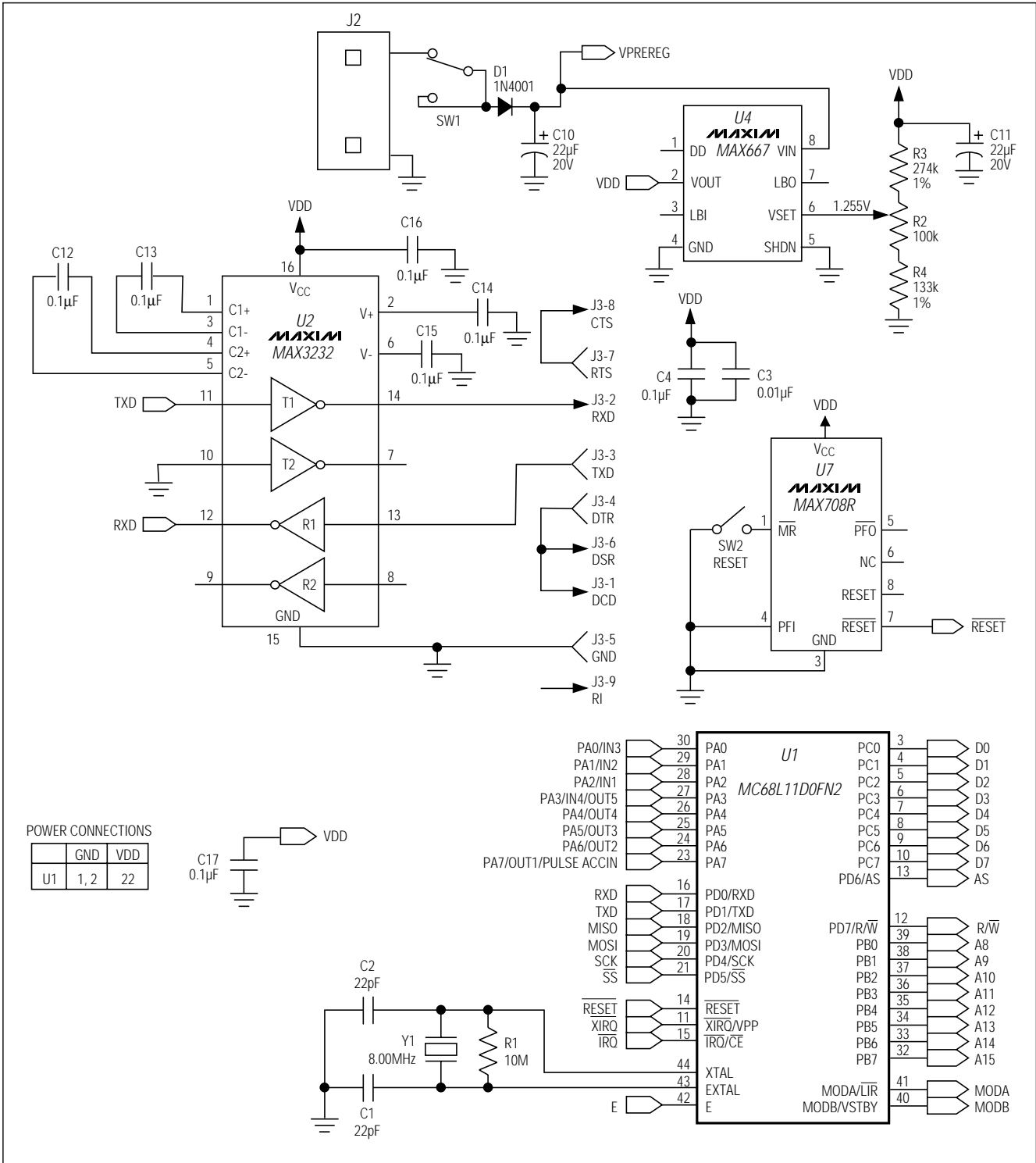

Figure 1. 68L11D Module Schematic Diagram

# 68L11D Module

68L11D Module

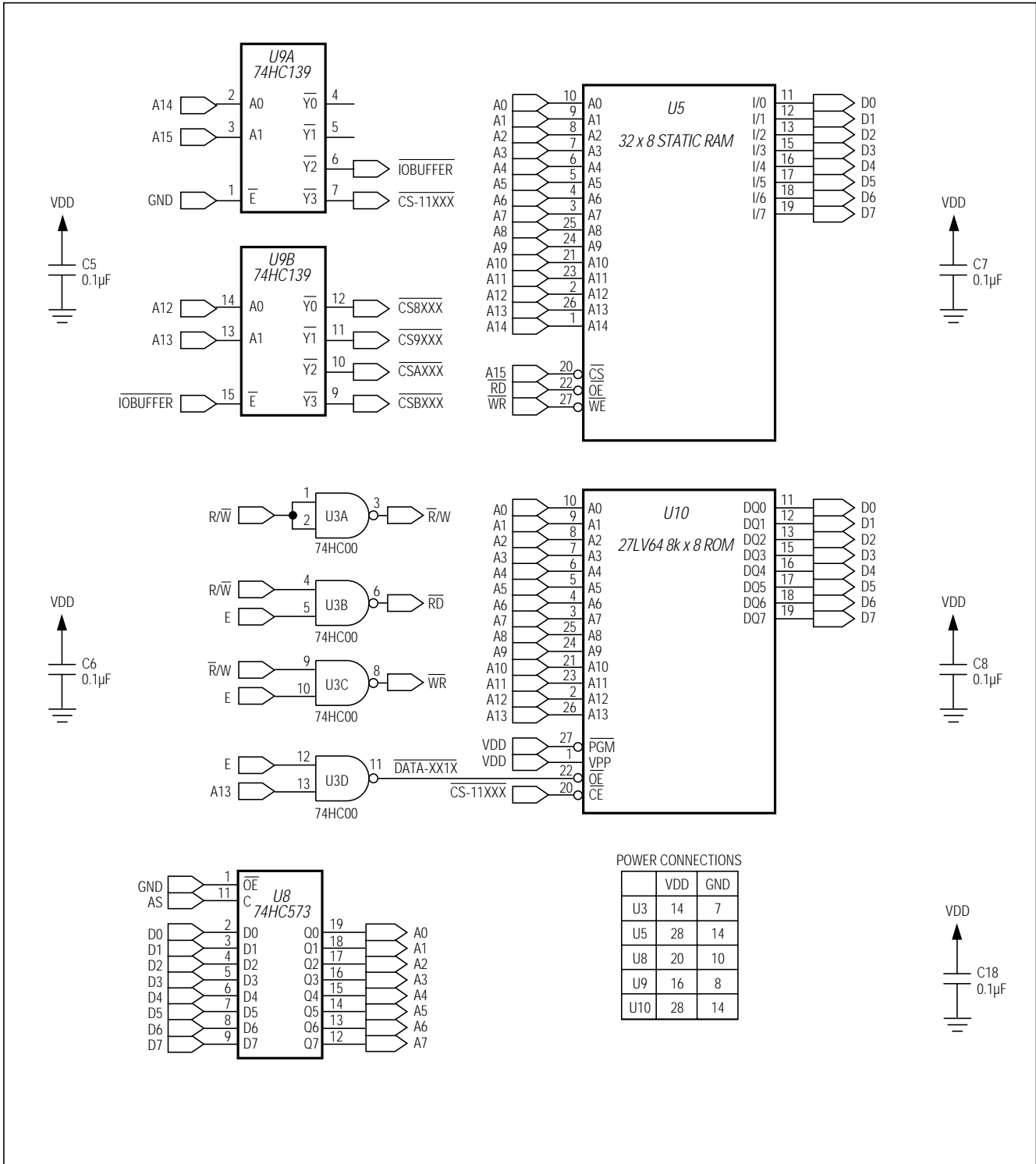

Figure 1. 68L11D Module Schematic Diagram (continued)

# 68L11D Module

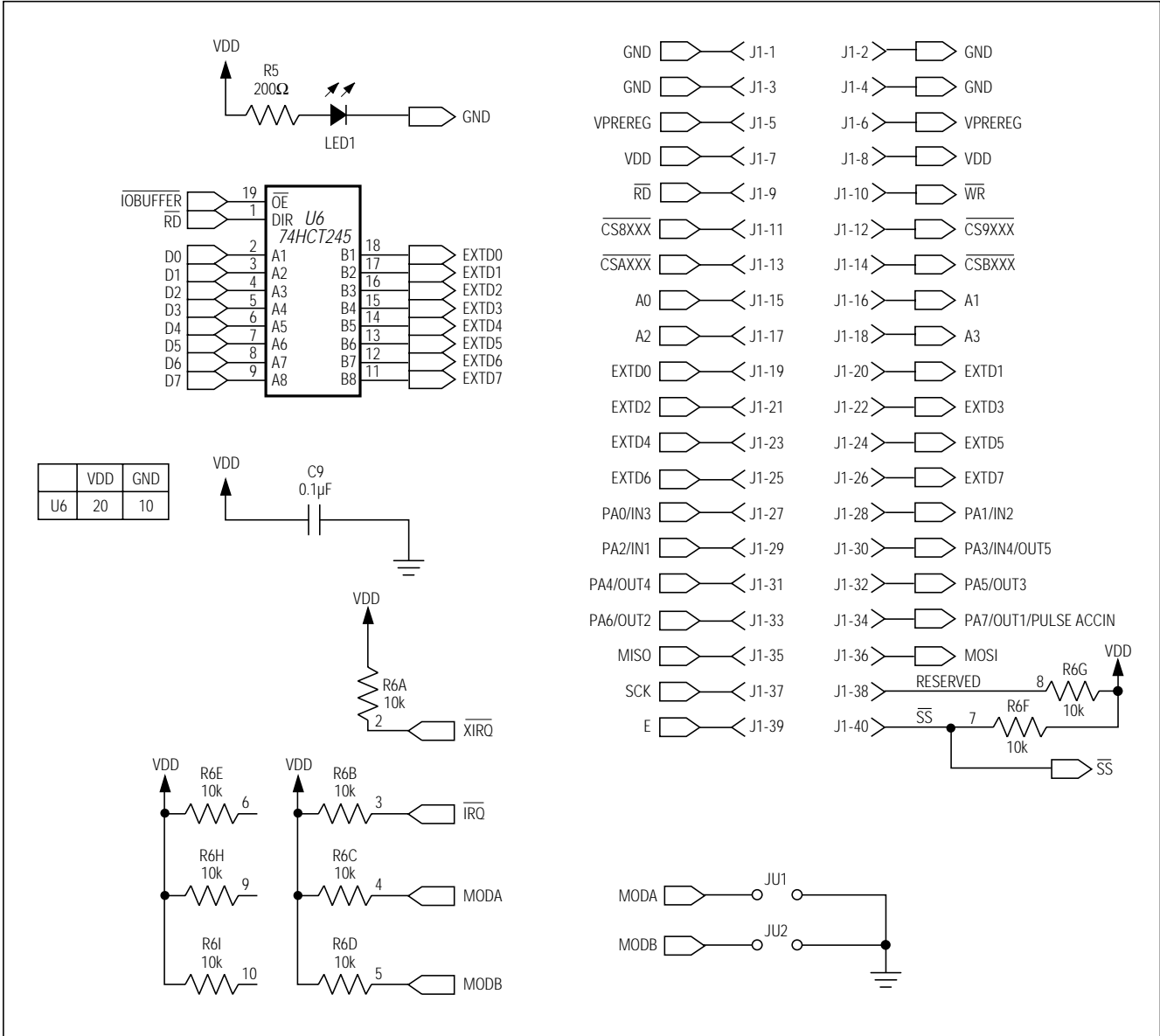

Figure 1. 68L11D Module Schematic Diagram (continued)

# 68L11D Module

68L11D Module

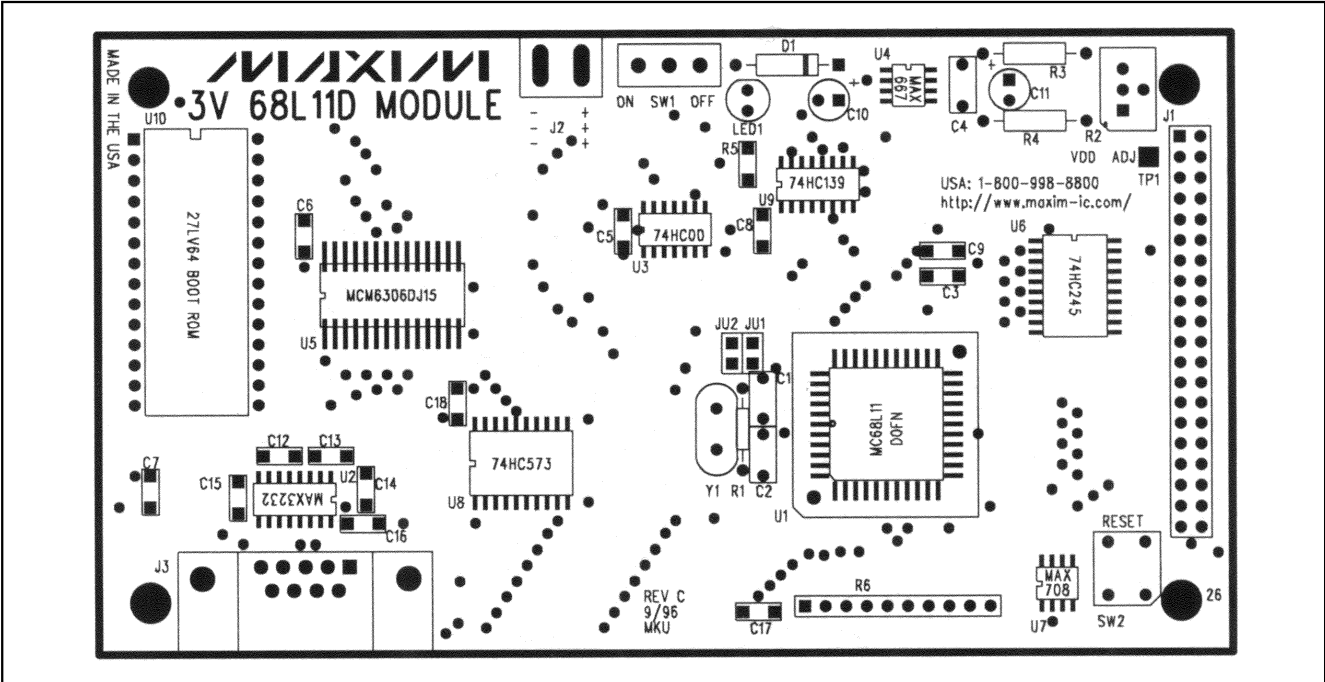

Figure 2. 68L11D Module Component Placement Guide

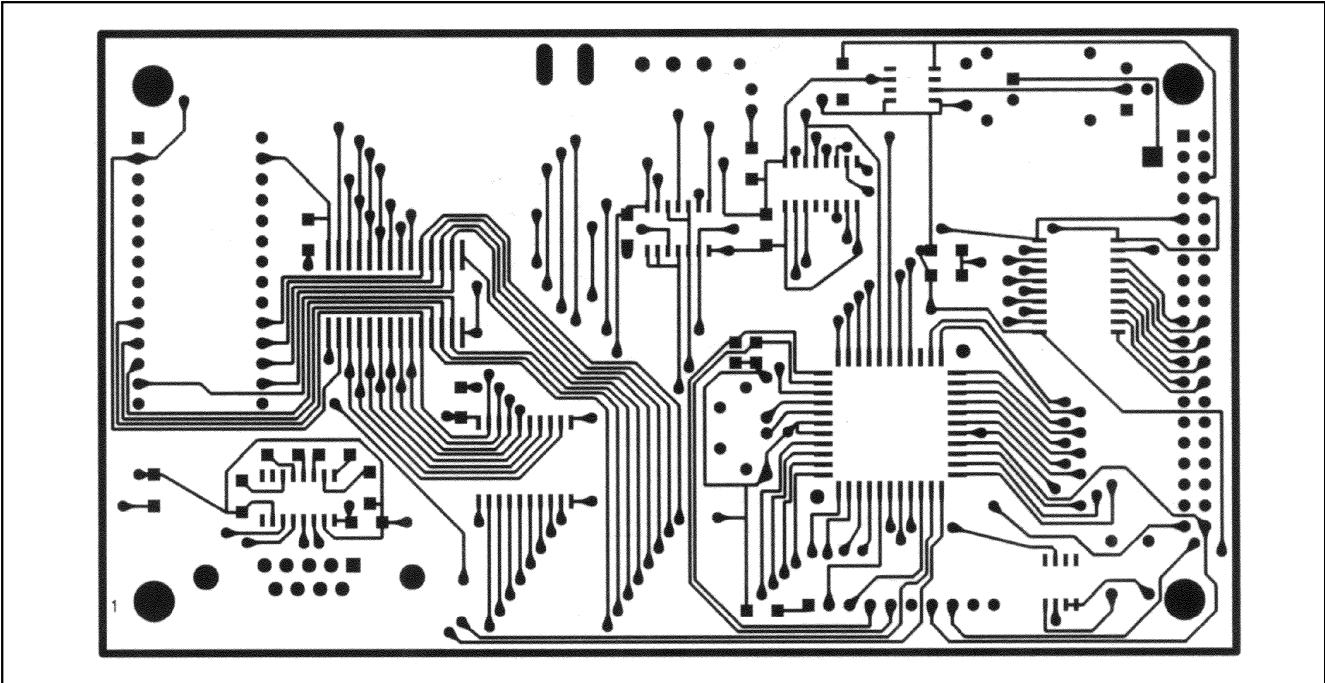

Figure 3. 68L11D Module PC Board Layout—Component Side

# 68L11D Module

68L11D Module

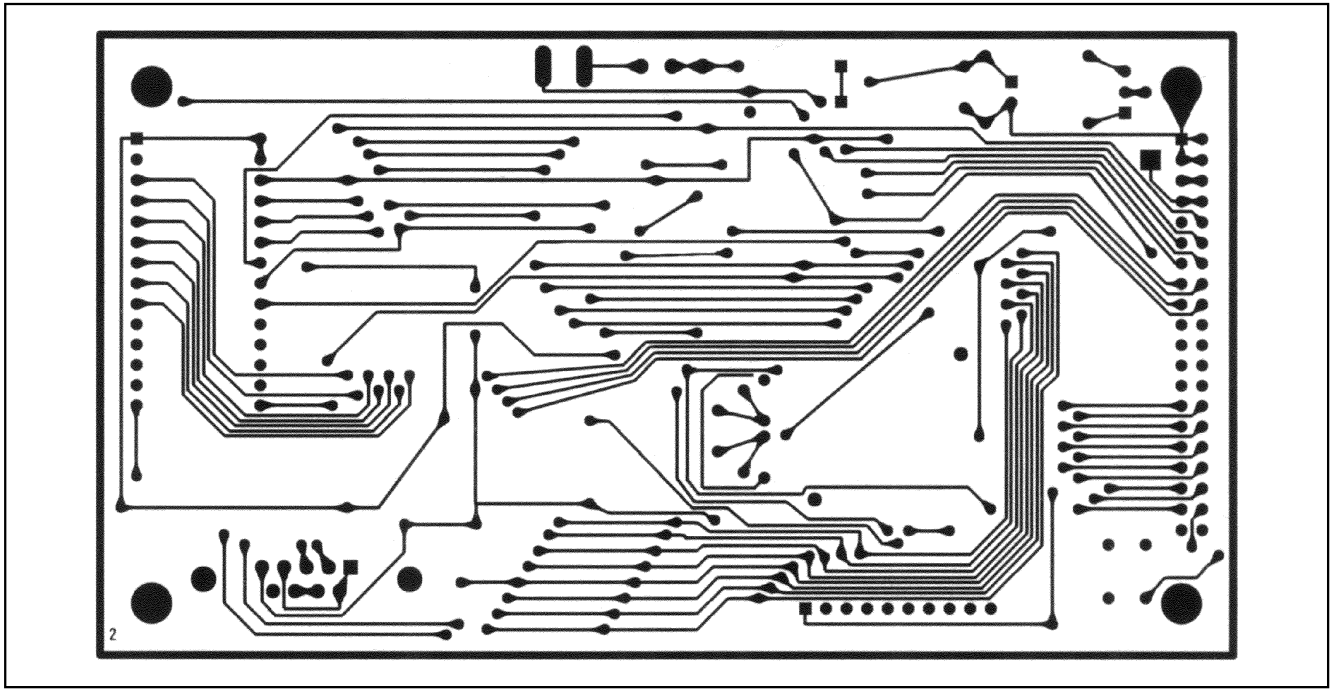

Figure 4. 68L11D Module PC Board Layout—Solder Side

Maxim cannot assume responsibility for use of any circuitry other than circuitry entirely embodied in a Maxim product. No circuit patent licenses are implied. Maxim reserves the right to change the circuitry and specifications without notice at any time.

8 \_\_\_\_\_ Maxim Integrated Products, 120 San Gabriel Drive, Sunnyvale, CA 94086 408-737-7600

© 1999 Maxim Integrated Products

Printed USA

**MAXIM** is a registered trademark of Maxim Integrated Products.