

Set top box

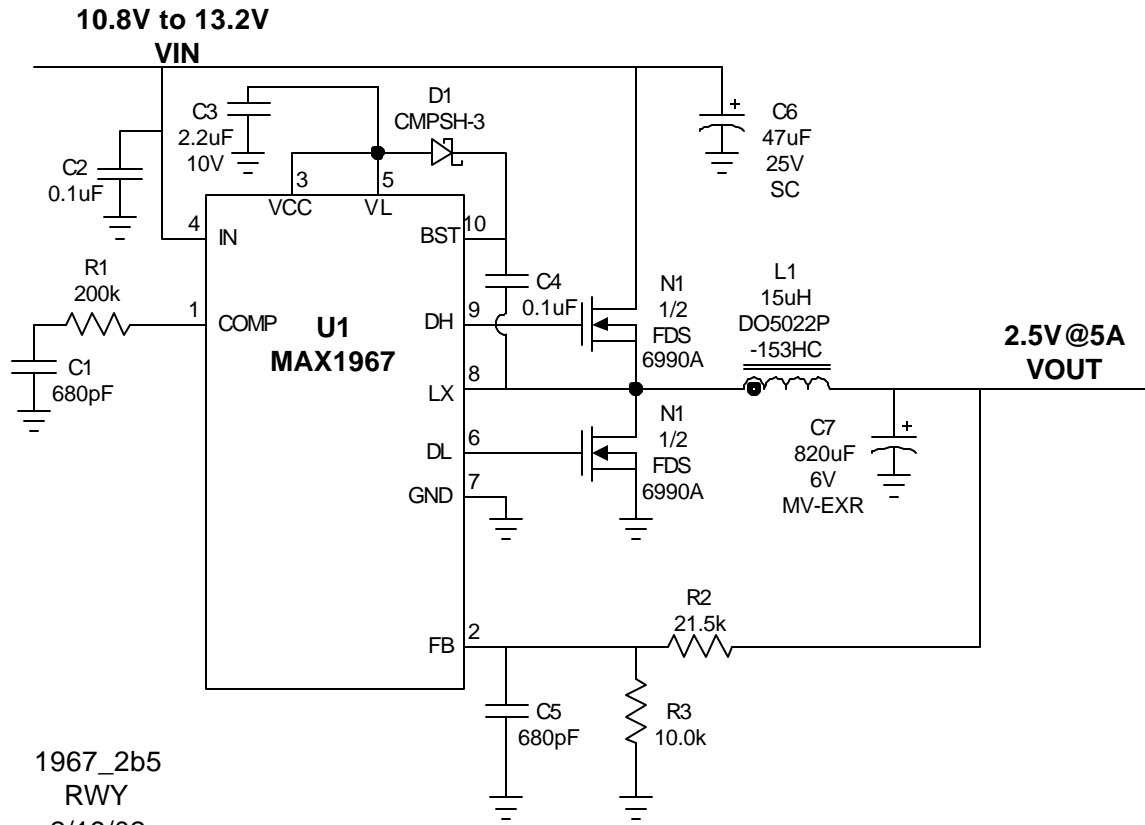

Vin	Iin	Vout	Iout	Efficiency
10.866	0.011	2.5246	0	
10.783	1.313	2.4630	5.0023	0.870
12.009	1.182	2.4588	5.0024	0.866
13.222	1.076	2.4555	5.0024	0.863
		50mVpp		

BILL OF MATERIALS
10.8V to 13.2V Input
2.5V @ 5A Output
2/19/02

1967_2b5

DESIGNATION	QTY	DESCRIPTION
C1,C5	2	680pF ceramic capacitor (0805)
C2,C4	2	0.1uF ceramic capacitor (0805)
C3	1	2.2uF 10V ceramic capacitor (0805) Taiyo Yuden LMK212BJ225MG
C6	1	47uF 25V aluminum electrolytic capacitor Sanyo OS-CON 25SC47M
C7	1	820uF 6V aluminum electrolytic capacitor Sanyo 6MV820EXR
D1	1	100mA 30V Schottky diode (SOT-23) Central Semi CMPSH-3
L1	1	15uH 8A Power inductor Coilcraft DO5022P-153HC
N1	1	Dual N-channel MOSFET (SO-8) Fairchild FDS6990A
R1	1	200k Ohm 5% resistor (0805)
R2	1	21.5k Ohm 1% resistor (0805)
R3	1	10.0k Ohm 1% resistor (0805)
U1	1	MAX1967EUB (10-uMAX)